

HARDINGE T-SERIES

SUPER-PRECISION[®] TURNING CENTERS

HARDINGE T-42

HARDINGE T-51

HARDINGE T-65



HARDINGE T-SERIES

SUPER-PRECISION® TURNING CENTERS

KEY DIFFERENTIATORS

- High degree of machine stiffness qualified by Finite Element Analysis
- High surface finish capability of eight micro-inch or better
- Ball bar testing for superior geometric accuracy
- Dynamic balancing of spindle and drive motor
- Integral wrap around spindle motor technology to eliminate belts
- Matched high precision spindle bearings
- Ability to maintain 0.00012" 3 micron total deviation in diameter after a brief warm-up
- High repeatability accuracy – 30 millionths (.00003")
- Robust control/motor/drive package with 10 millionths (.00001") control resolution
- High accuracy X-axis digital glass scales

Super-Precision is a combination of best practice, design and manufacturing of hardware and software integrated into a machine tool that provides the highest level of precision for production turning centers that require the least amount of human intervention in the marketplace today.

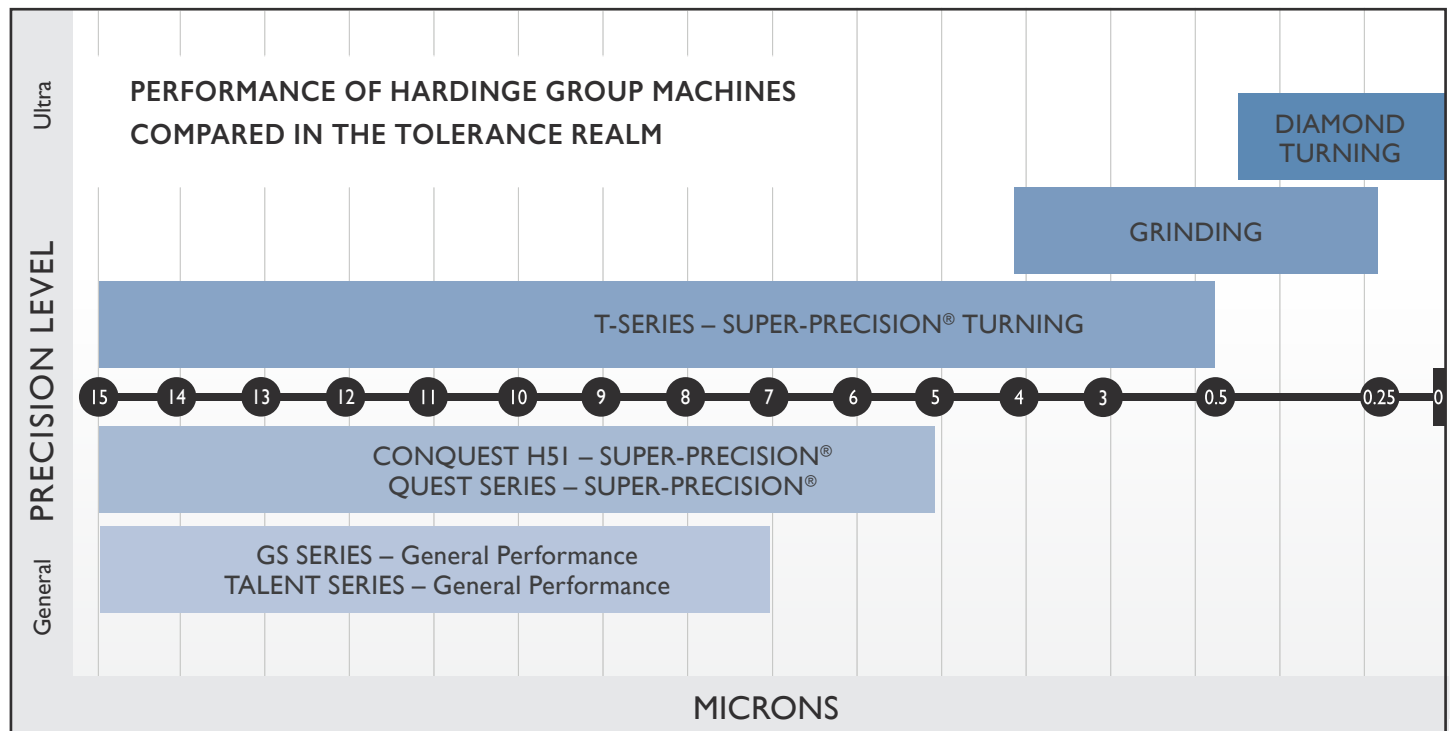

COMPONENT DEMONSTRATION

Summary of SUPER-PRECISION® demonstration

- Machine Model: SUPER-PRECISION® T-42
- Material 8620 Steel 60-62 Rc
- Surface Finish ≤ 8 micro-inch
- Holding tolerances normally reserved for grinding
- Workholding – Hardinge I6C collet
- Cutting Tools – Sandvik CBN grade 7015 certified TNR
- Zeiss Rondcom 54 Form Tester
– measurement verification



CUT #1

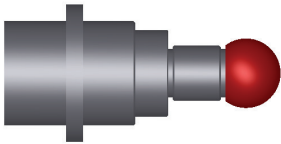

- 1.00" Diameter Sphere
- Profile Tolerance = $\pm 0.000060''$ ($\pm 1.5 \mu\text{m}$)

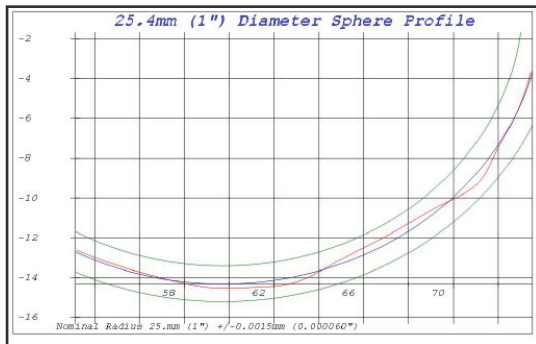

CUT #3

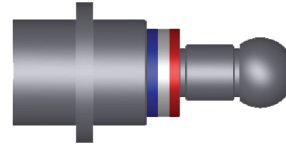

- Small steps $.000050''$ ($1.2 \mu\text{m}$)
- $\pm .000010$ tolerance ($\pm 0.25 \mu\text{m}$)

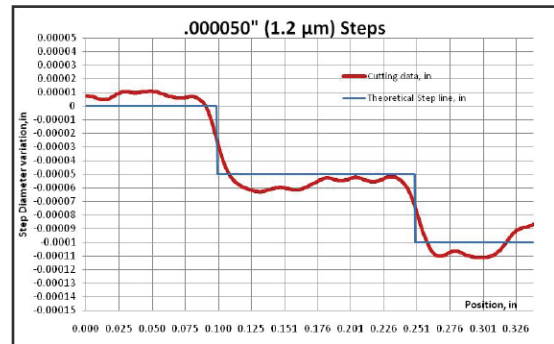

CUT #2

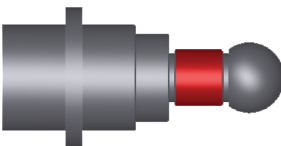

- Profile Tolerance $\pm .000030''$ ($.7 \mu\text{m}$)
- $0.00015''$ ($3.8 \mu\text{m}$) chord height

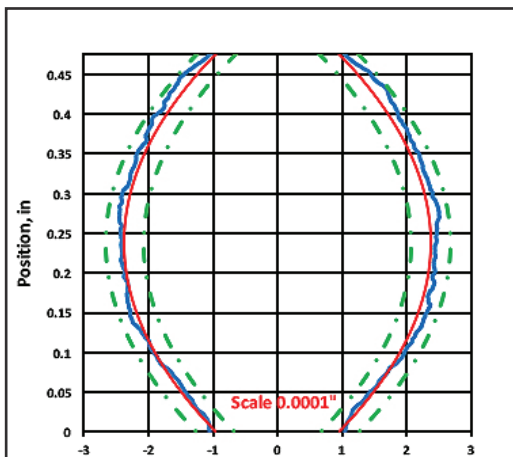

CUT #4

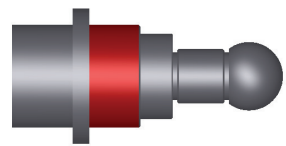

- Cylindricity = $.000040''$ ($1 \mu\text{m}$)

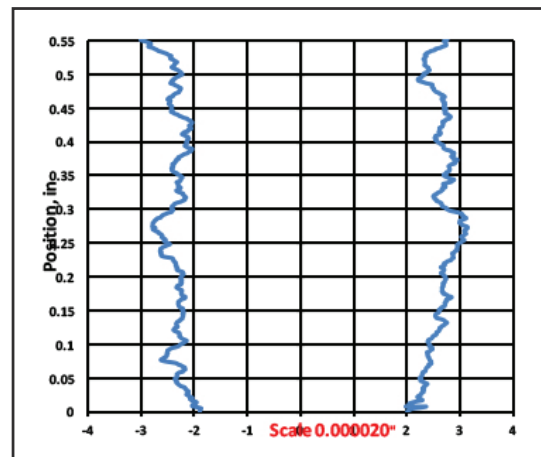

HARDINGE T-SERIES



The Hardinge T-Series turning centers are the recognized market leader in Super Precision and hard turning applications providing superior SPC (Statistical Process Control), precise micron part size control and repeatability, high surface finish capability, and thermal stability with minimal human intervention allowing the most complex parts to be manufactured to the highest precision and quality standards.

- “Soft turn” and “hard turn” on the same machine
- Less floor space requirement
- Lower overall investment
- Metal removal rates of four to six times greater
- Eliminate operations
- Multiple operations in a single setup
- Finer micro finishes
- Easier Part configuration changes
- Lower cost tooling inventory
- Easier waste management (chips vs. “swarf”)

The Hardinge SUPER-PRECISION® T-Series turning centers set the standard in high-precision and high-performance turning that will take your part quality and manufacturing capabilities to new heights. T-Series machines are designed to exceed your expectations and are ideal for two axis high-precision machining or complex multi-tasking operations that require a high level of precision, delicate part handling and for parts made complete in a single setup. Machine packages are pre-configured with our most popular features allowing you to select the proper machine tool configuration to produce your parts in the most effective and profitable manner.

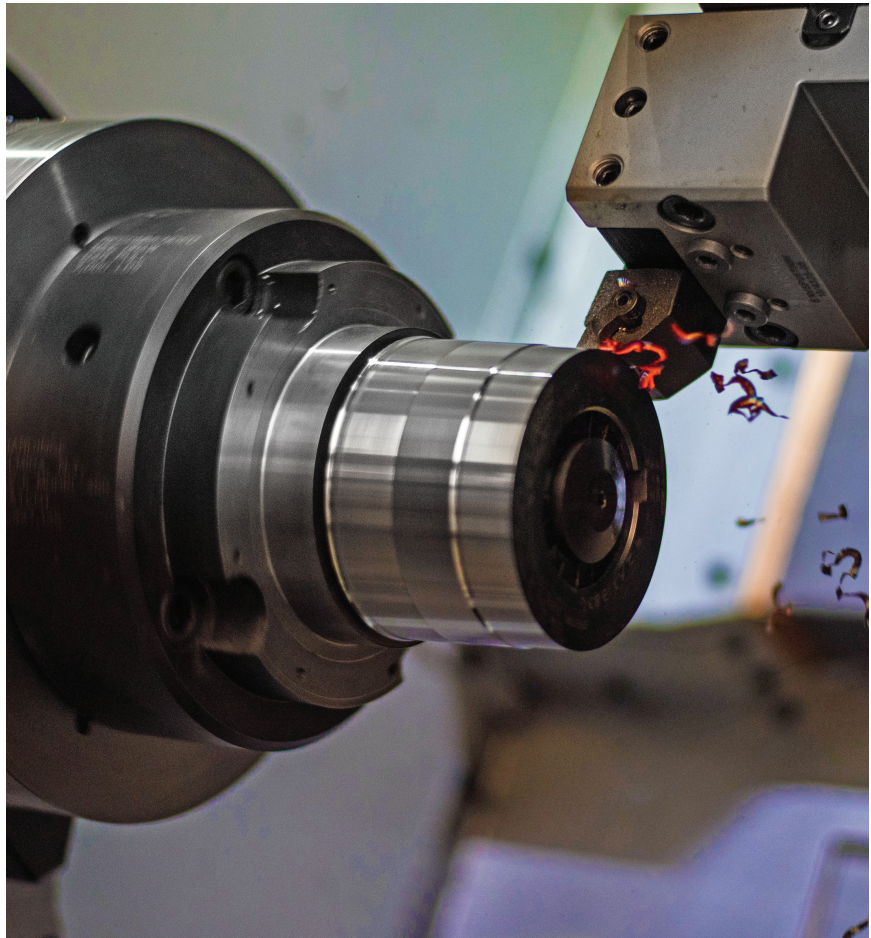

HARDINGE T-SERIES MODELS

STANDARD SPECIFICATIONS

T-42 Y YT YS MSY MYT

- Spindle Nose: A2-5 / 16C (A2-6 / 20C Big Bore Option)
- Collet Capacity (in/mm): 1.625 / 42 (2 / 51 Big Bore Option)
- Spindle Through Hole (in/mm): 1.890/48 (2.373 / 60.4 Big bore)
- Chuck Size (Chuck not Included) (in/mm) 6/150 (8 / 200 Big bore)
- Spindle Motor (hp/kW): 15 / 11
- Max Spindle Speed (rpm): 6,000 (5,000 Big Bore Option)
- Number of Turret Stations (BMT-45 / block type): 16 / 12
- CNC Control: Fanuc 3iTB



STANDARD SPECIFICATIONS

T-51 Y YT YS MSY MYT

- Spindle Nose: A2-6 / 20C
- Collet Capacity (in / mm): 2 / 51
- Spindle Through Hole (in / mm): 2.378 / 60.4
- Chuck Size (Chuck not included) (in / mm): 8 / 200
- Spindle Motor (hp / kW): 20 / 15
- Max Spindle Speed (rpm): 5,000
- Number of Turret Stations BMT-55 / block type): 12 / 12
- CNC Control: Fanuc 3iTB



STANDARD SPECIFICATIONS

T-65 Y YT YS MSY MYT

- Spindle Nose: A2-6 / 25C
- Collet Capacity (in/mm): 2.5 / 65
- Spindle Through Hole (in/mm): 2.930 / 74.4
- Chuck Size (Chuck not Included) (in/mm): 10 / 250
- Spindle Motor (hp/kW): 35 / 26
- Max Spindle Speed (rpm): 4,000
- Number of Turret Stations (BMT-55 / block type): 12 / 12
- CNC Control: Fanuc 3iTB



KEY FEATURES

COLLET-READY SPINDLE ADVANTAGES

- Collet seats directly in the Hardinge spindle
- Maximum rigidity and gripping power is transferred to the part
- Maximum utilization of RPM
- Minimum weight on spindle
- Minimum overhang from the spindle bearings that assures spindle accuracy is transferred directly to the workpiece
- Optimum T.I.R.
- Gripping force directly over the workpiece
- Superior tolerances and finishes
- Capable of using maximum machine stroke capacity
- Longer tool life
- Quick changeover

LIVE TOOLING

Live tool holders start at 8,000 RPM and are capable of up to 32,000 RPM when purchased with ratios of 2:1 or 4:1 when high speeds are required. The Hardinge BMT live tooling holders provide superior run-out within .00012" (3 micron) making it the overall best in class tooling system.

TURRET & TOP PLATE

The Hardinge BMT-45 Live Tooling Top Plate with Tenon tool drive system provides 16 live tooling stations with 1/2 station index between each station providing 32 stations. The Hardinge BMT-55 has 12 and 24 station respectively.

Both the static and live tool holders are designed to adapt modular add-on tool holder blocks providing the ultimate in overall tooling flexibility. The unique Hardinge BMT system also allows fine adjustment of tools in the Y-axis plane for machines without a true Y-axis for pinpoint tool alignment. Our tooling system is keyed for precision and provides unparalleled station to station tooling accuracy and repeatability.

HARDINGE T-STYLE TOP PLATE (STATIC)

- Optional T-style top plate
- Utilizes T-series tool holders
- 12-station static only
- Sq. Shank: T42: 3/4" (20mm)
T51 & T65 1" (25mm)
- Rd. Shank: T42: 1.25" (32mm)
T51 & T65 1.5" (40mm)

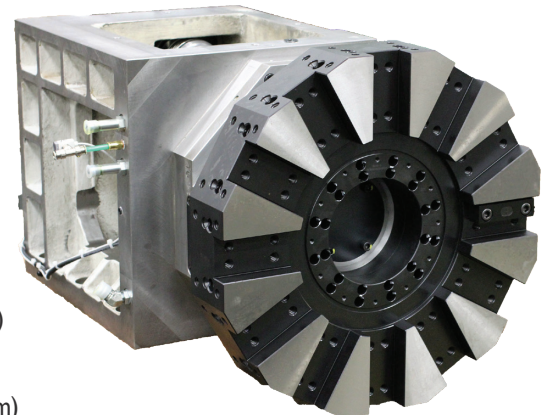
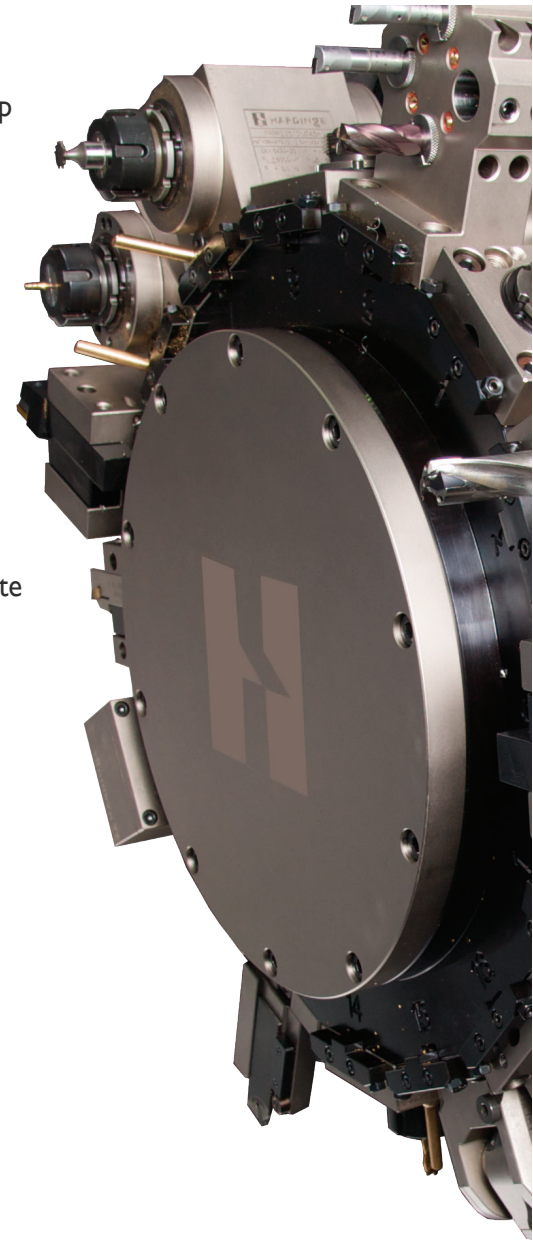

MACHINE CONSTRUCTION

COLLET-READY MAIN SPINDLE

The Hardinge collet-ready spindle is the most versatile machine spindle in the industry – it is uniquely designed to accept both collets and jaw chucks without the use of an adaptor. Because the collet seats directly in the spindle, the workpiece is held close to the spindle bearings which provides the ultimate in accuracy, rigidity and gripping force. It also allows for maximum spindle RPMs which increases productivity. This exclusive design also offers numerous workholding capabilities including solid collets, master collets, dead length collets, step chucks, 3-jaw chucks and FlexC collets systems.

LINEAR GLASS SCALE

The Heidenhain closed-loop linear scale system on the X,Y, Z axes provide direct measurement to compensate for any ballscrew thermal growth and wear ensuring the highest accuracy through the most demanding duty cycles and over the life of the machine.

ROBUST 45° BASE STRUCTURE

The one-piece 45 degree slant bed design greatly inhibits thermal deformation and twisting, allowing for SUPER-PRECISION® cutting performance and demanding part accuracies.

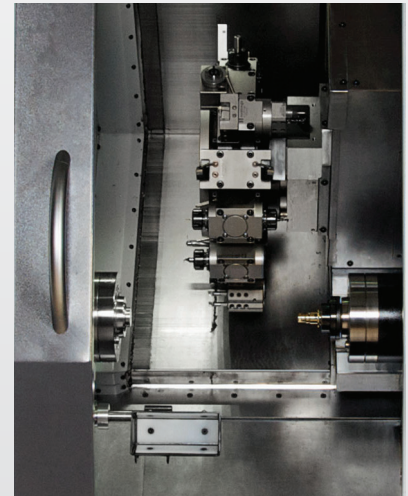

TAILSTOCK

The servo driven tailstock features a non quill style body and is fully programmable with torque control to set the tailstock force, as well as advance or retract between machining cycles. Multiple positioning is possible to allow for multiple bar feed out applications. The system will accommodate either a live or dead center with a #4 Morse taper.

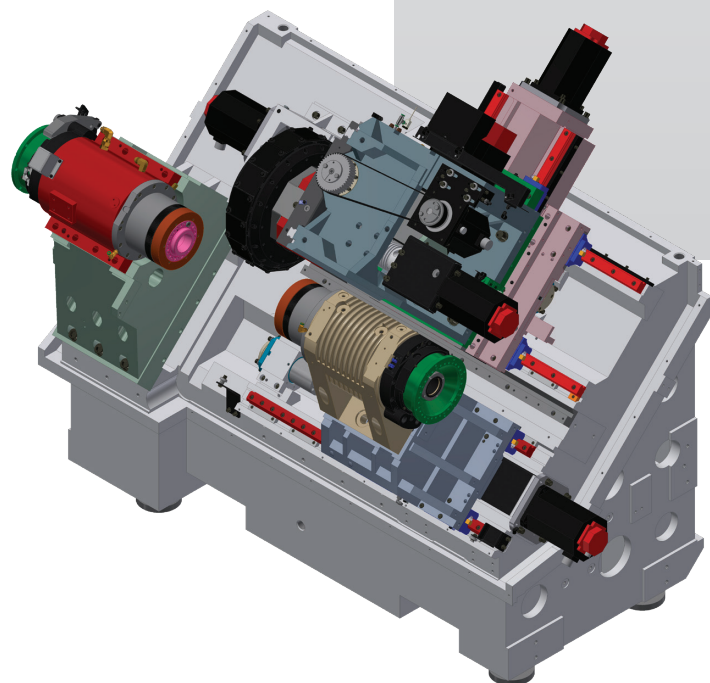

FLOOR PLAN T-42

FRONT VIEW

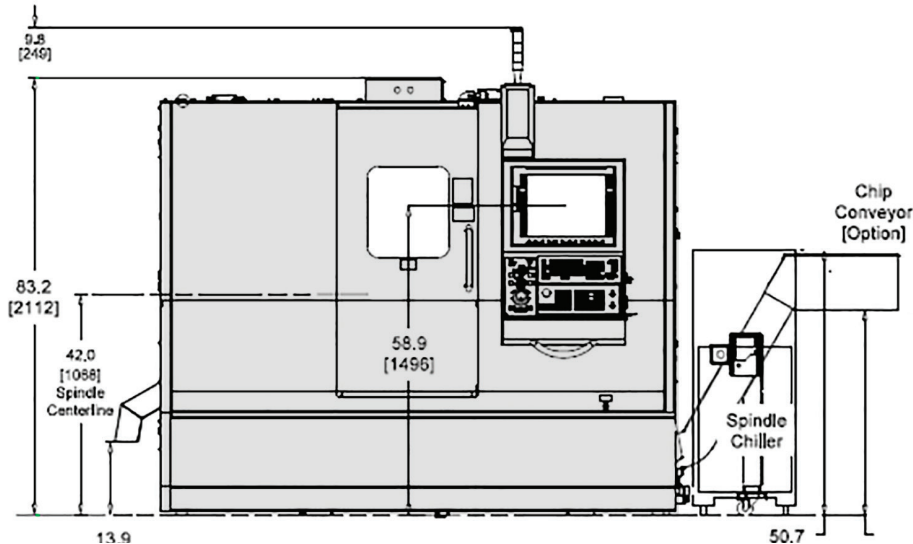

TOP VIEW

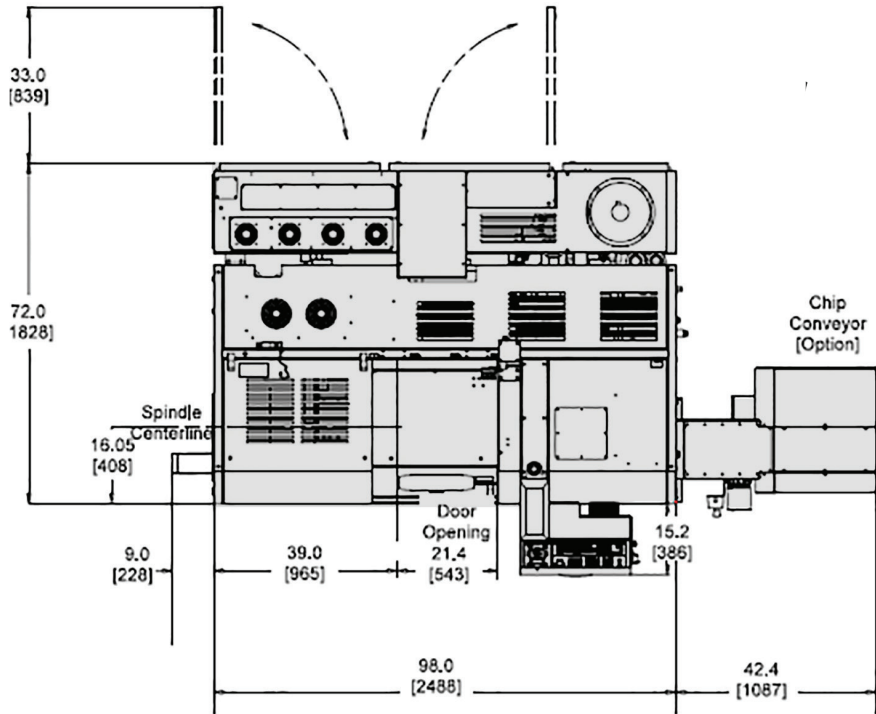

FLOOR PLAN T-51 & T-65

FRONT VIEW

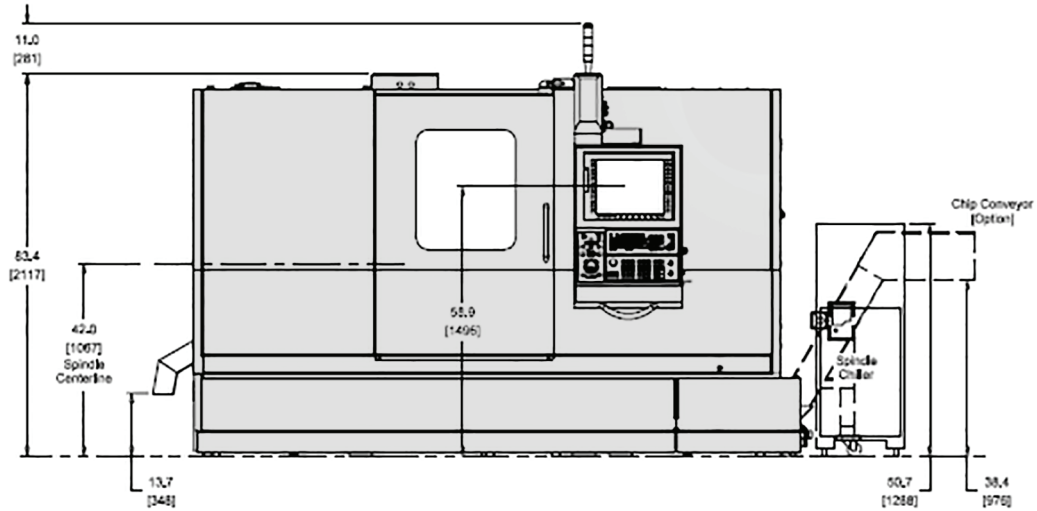

TOP VIEW

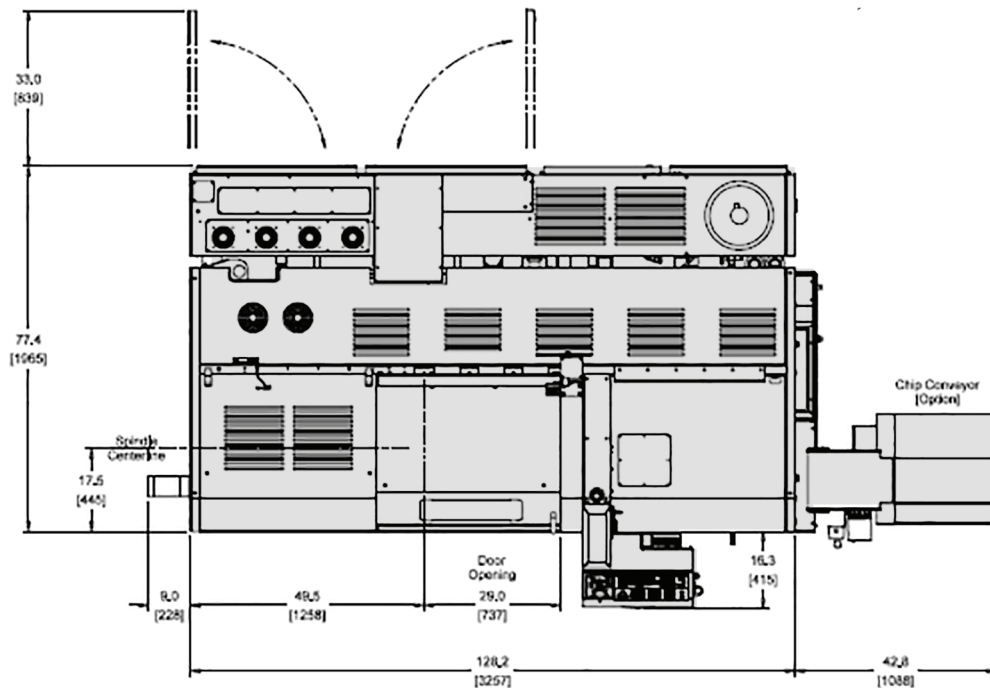

CONTROLS: FANUC 31i TB

INCLUDED CONTROL FEATURES

- 99 Geometry/Wear offsets (XYZR)
- Inch/Metric Selection by G-Code
- 160 Meters (64Kbyte) Part Program Storage
- Absolute/Incremental Programming
- Alarm Display
- Auto Coordinate System Setting
- Background Editing
- Block Skip
- Canned Cycles (Turning/Drilling)
- Chamfer/Corner Rounding
- Circular Interpolation by R Programming
- Constant Surface Speed Programming
- Continuous Thread Cutting
- Coordinate System Setting (G50)
- Custom Macro B
- Decimal Point Programming
- Diameter/Radius Programming
- Direct Drawing Dimension Programming
- Display Position, Program, Alarm, History,
- Ethernet ready
- Extended Part Program Edit (copy/replace)
- External Workpiece Number Search
- Floating Reference Point Return
- Helical Interpolation (All M S models)
- Help Screen
- Input of Offset Values by (G10)
- Interpolation (Linear/Circular)
- Machine Lock/Dry Run
- Manual Guide i with full color display
- Program Number Search
- Programmable Parameter Input
- Reference Point Return
- Registered Part Program Storage (1000)
- Rigid Tapping – All Spindles
- Run time parts counter
- Self-Diagnostic Function
- Spindle Orient (One degree)
- Spindle Synchronization (All S models)
- Sequence Number Search
- Single Block Operation
- Skip Function G31
- Stored Stroke Check 2 & 3
- Straightness Compensation
- Sub Program Call (10-fold nested)
- Thread Cutting
- Tool Nose Radius Compensation
- Workpiece Coordinate System (G52-G59)
- Program Protect



CONTROL OPTIONS: ALL CONFIGURATIONS

- Additional Hard Drive 32GB or 64GB or 128GB
- Additional Custom Macro Variables (500)
- Additional Custom Macro Variables (1050)
- Floating Reference Return
- Multiple Repetitive Cycles II (Pockets)
- Thread Cutting Cycle Retract
- Variable Lead Threading
- Arbitrary Speed Threading
- Circular Thread Cutting
- Circular Thread Cutting B
- Tool Offsets 200 Pair
- Tool Offsets 400 Pair
- Tool Offsets 499 Pair
- Tool Offsets 999 Pair
- Tool Offsets 2000 Pair
- Manual Handle Retrace
- Tool Retract and Recover
- Part Program Storage – 320M (128K)
- Part Program Storage – 640M (256K)
- Part Program Storage – 1280M (512K)
- Part Program Storage – 2560M (1MB)
- Part Program Storage – 5120M (2MB)
- Part Program Storage – 10240M (4MB)
- Part Program Storage – 20480M (8MB)
- Polygon Turning (M models)
- Additional Workpiece Coordinate System (48 pairs)
- 3D Coordinate System Conversion (MY models)
- 6500 I/O Device
- Tool Management Function (64 pair)
- Tool Management Function (240 pair)
- Tool Management Function (1000 pair)
- Energy Saving Level Set Function
- Unexpected Disturbance Torque Function
- Axis Synchronous control (MSY model)

MACHINE OPTIONS

- Sub-Spindle Part Present Detector
- Big Bore Main Spindle (A2-6/20C, 2"/51mm Bar Capacity)
- Marposs Tool Touch Probe
- Marposs Part Probe, Wireless
- Auto Door
- Main Spindle Part Catcher with Conveyor
- Sub Spindle Part Catcher with Conveyor
- Remote MPG
- Sub Spindle Part Ejector (for sub machines with main part catcher)
- Spindle Liner Kit Includes (3) steel spacers and (4) nylon bushings
- Spindle Liner Bushing (3 required for each bar stock size)
- CSA Specification (Canada)
- Power case air conditioner
- Auto Grease System
- Hardinge Standard Automation Interface
- LNS Chip Conveyor

Conversational programming features offered on the CNC control is the CNC control builder's standard product, which may not fully support all machine functions. It is recommended the end user reference the control system documentation, or contact the control manufacturer, for further details of use or customization.

SPECIFICATIONS

	T-42	T-51	T-65
Max. Swing Over Way Covers	27" (685.8mm)	29.88" (758.9mm)	29.88" (758.9mm)
Chuck Size	6" (150mm)	8" (200mm)	10" (250mm)
Max. Bar Capacity	1.625" (42mm)	2" (51mm)	2.5" (65mm)
Max. Machining Diameter (BMT)	9.41" (239mm)	12.35" (313.7mm)	12.35" (313.7mm)
Max. Machining Diameter (T-Style)	12.9" (327.7mm)	15.245" (387.2mm)	15.245" (387.2mm)
Max. Machining Length w/Tailstock BMT	14.2" (360.6mm)	22.47" (570.7mm)	22.47" (570.7mm)
Max. Machining Length w/Tailstock Hardinge T-style	14.9" (378.5mm)	23.6" (599.4mm)	23.6" (599.4mm)
Max. Machining Length w/Chuck BMT	9.63" (244.6mm)	16.85" (428mm)	15.70" (398.65mm)
Max. Machining Length w/Chuck Hardinge T-style	10.3" (261.6mm)	17.99" (456.8mm)	16.83" (427.36mm)
Max. Speed	6000-rpm	5000-rpm	4000-rpm
Max. Power Rating (cont.)	15-hp (11 kW)	20-hp (15 kW)	35-hp (26 kW)
Max. Torque (cont.)	108 ft-lb (146.3 Nm)	256 ft-lb (347 Nm)	311 ft-lb (421 Nm)
Base Speed	750-rpm	420-rpm	590-rpm
Spindle Nose	A2-5 / 16 C	A2-6 / 20 C	A2-6 / 25 C
Chuck Size (chuck not included)	6" (150 mm)	8" (200 mm)	10" (250 mm)
Spindle Bore (not bar capacity)	1.89" (48mm)	2.378" (60.4mm)	2.935" (75mm)
Spindle Center Height	42" (1066.8mm)	42" (1066.8mm)	42" (1066.8mm)
Spindle Reach	16" (406.4mm)	17.5" (444.5mm)	17.5" (444.5mm)
Spindle Orient (opt.)	1.0 degree	1.0 degree	1.0 degree
Closer Type	Hydraulic	Hydraulic	Hydraulic
Max. Hang Weight	100 lbs. (45.3kg)	300 lbs. (136kg)	300 lbs. (136kg)
Max. Speed	6000-rpm	5000-rpm	5000-rpm
Max. Power Rating (cont.)	15-hp (11 kW)	15-hp (11 kW)	15-hp (11 kW)
Max. Torque (cont.)	108 ft-lb (146.3 Nm)	108 ft-lb (146.3 Nm)	108 ft-lb (146.3 Nm)
Base Speed	750-rpm	750-rpm	750-rpm
Spindle Nose	A2-5 / 16 C	A2-6 / 20 C	A2-6 / 20 C
Chuck Size (chuck not included)	6" (150 mm)	6" (150 mm)	6" (150 mm)
Spindle Bore (not bar capacity)	1.89" (48mm)	2.378" (60.4mm)	2.378" (60.4mm)
Spindle Center Height	42" (1066.8mm)	42" (1066.8mm)	42" (1066.8mm)
Spindle Reach	16" (406.4mm)	16" (406.4mm)	16" (406.4mm)
Spindle Orient (opt.)	1.0 degree	1.0 degree	1.0 degree
Closer Type	Pneumatic	Pneumatic	Pneumatic
Max. Travel	16" (406.4mm)	25.125" (638mm)	25.125" (638mm)
Max. Traverse Rate	1200-ipm (30.5m/min)	1500-ipm (38m/min)	1500-ipm (38m/min)
Max. Distance from Sub to Main Spindle Face	16.5" (419.1mm)	25.75" (654.1mm)	25.75" (654.1mm)
Min. Distance from Sub to Main Spindle Face	.5" (12.7mm)	.625" (15.8mm)	.625" (15.8mm)
Max. Hang Weight	100 lbs. (45.3kg)	100 lbs. (45.3kg)	100 lbs. (45.3kg)

SPECIFICATIONS

	T-42	T-51	T-65
Max. X-Axis Travel	6.37" (161.8mm)	7.76" (197mm)	7.76" (197mm)
Max. Z-Axis Travel	16" (406.4mm)	25" (635mm)	25" (635mm)
Max. Y-Axis Travel	3.25" (82.55mm)	3.50" (88.90mm)	3.50" (88.90mm)
Continuous Z-Axis Thrust	1,500 lbs. (6,672N)	2,250 lbs (10,008N)	2,250 lbs (10,008N)
X-Axis Rapid Traverse Rates	945-ipm (24m/min)	1100-ipm (28m/min)	1100-ipm (28m/min)
Z-Axis Rapid Traverse Rates	1200-ipm (30.5m/min)	1500-ipm (38m/min)	1500-ipm (38m/min)
Y-Axis Rapid Traverse Rates	500-ipm (12.7m/min)	500-ipm (12.7m/min)	500-ipm (12.7m/min)
BMT bi-directional	16-station + ½ station index	12-station + ½ station index	12-station + ½ station index
Square Shank	3/4" (20mm)	1" (25mm)	1" (25mm)
Round Shank Tooling	1.25" (32mm)	1.5" (40mm)	1.5" (40mm)
Index Time (rotation/including clamp-unclamp)	.35/1.45 sec	.35/1.35 sec	.35/1.35 sec
Tool Shank Dia. w/ER 25 Collets	.04 - .625" (1mm -16mm)	.04 - .625" (1mm -16mm)	.04 - .625" (1mm -16mm)
Live Tooling Power Rating (30 Min Rating)	7.5-hp (5.5 kW)	10-hp (7.5 kW)	10-hp (7.5 kW)
Live Tooling Torque Rating (30 Min Rating)	25 ft-lb (33 Nm)	31 ft-lb (42 Nm)	31 ft-lb (42 Nm)
Live Tooling Max Speed	8,000-rpm	8,000-rpm	8,000-rpm
Block Type (Static) bi-directional	12-station	12-station	12-station
Square Shank (Left, Right or Inverted Tooling)	3/4" (20mm)	1" (25mm)	1" (25mm)
Round Shank Tooling	1.25" (32mm)	1.5" (40mm)	1.5" (40mm)
Index Time (rotation/including clamp-unclamp)	.35/1.2 sec.	.35/1.2 sec.	.35/1.2 sec.
Morse Taper (no quill needed)	MT # 4	MT # 4	MT # 4
Max. Tailstock Travel	16" (406.4mm)	25.15" (638.8mm)	25.15" (638.8mm)
Max. Traverse Rate	1200-ipm (30.5m/min)	1500-ipm (38m/min)	1500-ipm (38m/min)
Min. Applied Force	350 lb. (1.55kN)	370 lb. (1.6kN)	370 lb. (1.6kN)
Max. Applied Force	1500 lb. (6.7kN)	1599 lb. (7.1kN)	1599 lb. (7.1kN)



SPECIFICATIONS

	T-42	T-51	T-65
Coolant Capacity	55 gallon (208 liter)	67 gallon (254 liter)	67 gallon (254 liter)
Max. Pressure	200 psi (13.8 bar)	200 psi (13.8 bar)	200 psi (13.8 bar)
Coolant Flow Rate (Per-Minute)	6.7 gallon (25.4 liters)	6.7 gallon (25.4 liters)	6.7 gallon (25.4 liters)
High Pressure Through Turret (Option)	1,000 psi (68.95 bar)	1,000 psi (68.95 bar)	1,000 psi (68.95 bar)
Part Surface Finish	12 micro-inch / .30 micron	12 micro-inch / .30 micron	12 micro-inch / .30 micron
Overall Axis Repeatability	.00005" / 1.27 micron	.00005" / 1.27 micron	.00005" / 1.27 micron
Program Resolution (non-SP)	.00001" (.0001mm)	.00001" (.0001mm)	.00001" (.0001mm)
Turret Indexing Repeatability	.000060" / 1.52 micron	.000060" / 1.52 micron	.000060" / 1.52 micron
Overall Axis Repeatability (X, Z)	.000030" (.76 micron)	.000030" (.76 micron)	.000030" (.76 micron)
Part Surface Finish	6 micro-inch (.15 micron)	8 micro-inch (.2 micron)	8 micro-inch (.2 micron)
Roundness	.00001" (.25 micron)	.00002" (.5 micron)	.000025" (.625 micron)
Total Variation on Diameter	.00012" (3 micron)	.00012" (3 micron)	.00012" (3 micron)
Program Resolution	.00001" (.0001mm)	.00001" (.0001mm)	.00001" (.0001mm)
Turret Indexing Repeatability	.000060" / 1.52 micron	.000060" / 1.52 micron	.000060" / 1.52 micron
Max. kVA/Full Load Amps	81 kVA/102FLA	89 kVA/112FLA	89 kVA/112FLA
Max. Voltage/Hz	400/50Hz, 460/60Hz	400/50Hz, 460/60Hz	400/50Hz, 460/60Hz
Phase/Hertz	3-phase/50-60 Hz	3-phase/50-60 Hz	3-phase/50-60 Hz
Lubrication	Grease	Grease	Grease
Communication	RS-232-C, Ethernet	RS-232-C, Ethernet	RS-232-C, Ethernet
Length	98" (2489.2mm)	128.23" (3257mm)	128.23" (3257mm)
Depth	85.24" (2165mm)	91.04" (2312.4mm)	91.04" (2312.4mm)
Height (no stack light)	82.25" (2089mm)	83.6" (2123mm)	83.6" (2123mm)
Approx. Weight	13,100 lb (5940kg)	17,200 lb (7800kg)	17,200 lb (7800kg)
Approx. Shipping Weight	13,600 lb (6170kg)	18,900 lb (8570kg)	18,900 lb (8570kg)
Air Requirement	70 - 90 psi (4.8-6.2 bar)	70 - 90 psi (4.8-6.2 bar)	70 - 90 psi (4.8-6.2 bar)



WORKHOLDING FLEXIBILITY

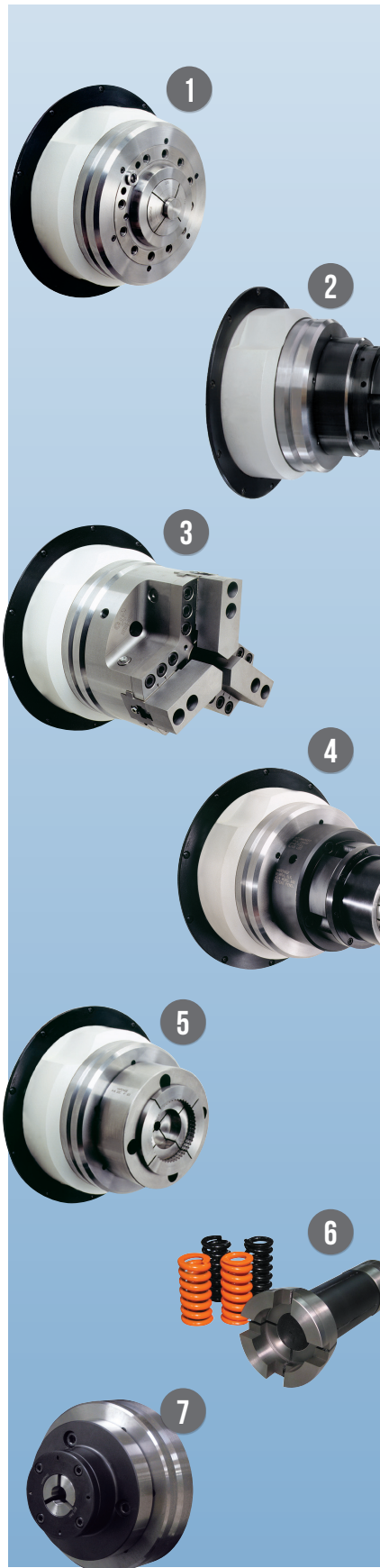

UNLIMITED FLEXIBLE WORKHOLDING OPTIONS

Hardinge is unique as a machine tool builder — we manufacture our own workholding products. Precision and accuracy is yours when you use Hardinge perfectly-mated workholding products.

1 COLLETS

Hardinge hardened and ground collets are inspected and measured in a Hardinge SUPER-PRECISION® spindle. Collets are available in fractional round, hex and square sizes and round metric, as well as round serrated fractional and metric sizes. Use adjustable, machinable collet stops for accurate part positioning.

EMERGENCY COLLETS

Emergency collets have a soft face with a pilot hole for customer drilling, boring and stepping out to the exact size required. An optional extended nose permits deeper counterbores when required and tool clearance for extended work.

2 FLEXC® QUICK-CHANGE VULCANIZED COLLET SYSTEMS

Interchangeable quick-change vulcanized collet heads have a working range of $\pm.020$ " (0.5mm) to accept bar stock variation. Collets change in seconds, while accuracy is maintained at $.0004$ " (.010mm).

STYLE "S" MASTER COLLETS AND PADS

pads can be changed much quicker than solid collets can. Pads cost less and use less storage space when compared to a standard solid collet. Choose from hardened and ground, semi-hard and emergency pads. Styles S16, S20 and S26 require a collet closer.

3 3-JAW POWER CHUCKS

Hardinge power chucks are lever operated, counter-centrifugal and dynamically balanced. Quick-change chucks are also available.

4 SURE-GRIP® EXPANDING COLLET SYSTEMS

The Hardinge Sure-Grip expanding collet provides high-precision, internal gripping solutions with true parallel gripping. Collet-style and spindle-mount styles are available, depending on the machine model.

Master Expanding Collets are a lower-cost alternative to Sure-Grip Expanding Collet Systems and include a dead-length feature.

5 STEP CHUCKS AND CLOSERS*

Step Chucks and closers are used to accurately hold larger diameter parts. * Main spindle only

6 FORCE-LIMITING STEP CHUCK

The Hardinge force-limiting step chuck has built-in force control to safely grip thin-wall parts. Maintain inside and outside concentricity in a fail-safe process while eliminating the nuisance of manually tweaking the draw bar.

7 DEAD-LENGTH® SYSTEMS

Maintain part-length control by using Hardinge dead-length systems. Choose from dead-length collet assemblies, thru-hole collets, step chucks and spider-stop step chucks. 16C to #22 B&S adapter shown on A2-5 sub-spindle.



BEARING RACE

MATERIAL _____ 52100 STEEL 60-62RC

TOTAL DIAMETRICAL
TOLERANCES ON OD & ID _____ .0002" (5 MICRON)

TRUE PROFILE OR
SPHERICITY OF RACE RADIUS _____ .0001" (3 MICRON)

PART ROUNDNESS _____ .000060" (1.5 MICRON)

SURFACE FINISH _____ 8RA OR BETTER



HARDINGE WORLDWIDE

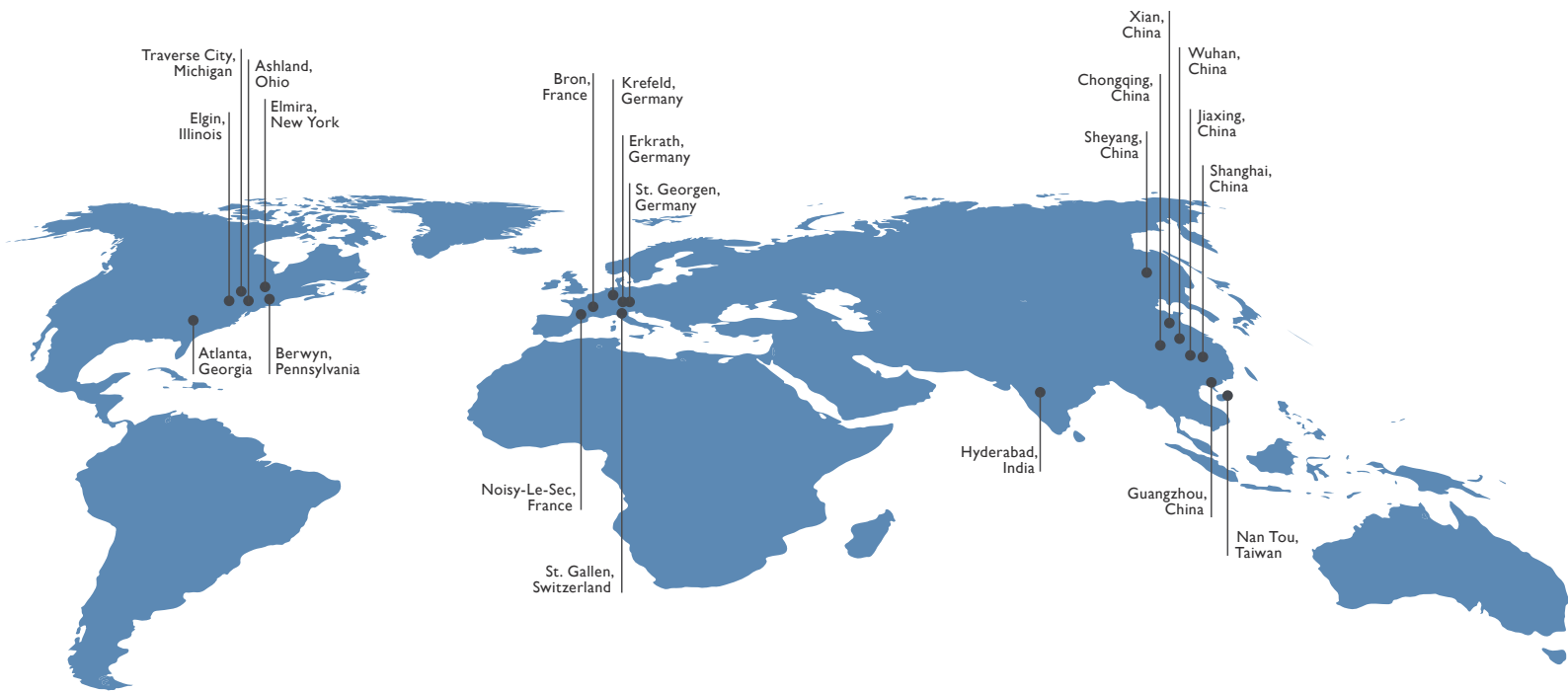

Hardinge is a leading international provider of advanced metal-cutting solutions. We provide a full spectrum of highly reliable CNC turning, milling, grinding, and honing machines as well as technologically advanced workholding accessories.

The diverse products we offer enable us to support a variety of market applications in industries including aerospace, agricultural, automotive, construction, consumer products, defense, energy, medical, technology, transportation and more.

We've developed a strong global presence with manufacturing operations in North America, Europe, and Asia. Hardinge applies its engineering and applications expertise to provide your company with the right machine tool solution and support every time.

AMERICAS

GEORGIA
Hardinge Corporate
79 W Paces Ferry Rd, 2F
Atlanta, GA 30305
P. 800.843.8801

ILLINOIS
Hardinge
1755 Britannia Dr
Unit 1A
Elgin, IL 60124

MICHIGAN
Forkardt
2155 Traversefield Dr
Traverse City, MI 49686
P. 800.544.3823
E. tcsales@forkardt.com

NEW YORK
Hardinge
1 Hardinge Drive
Elmira, NY 14903
P. 800.843.8801
E. info@hardinge.com

OHIO
Ohio Tool Works
1374 Enterprise Parkway (TR 743)
Ashland, OH 44805
P. 419.281.3700
E. sales@ohiotoolworks.com

PENNSYLVANIA
Hardinge
1235 Westlakes Drive
Suite 410
Berwyn, PA 19312

ASIA
CHINA
Hardinge Machine
(Shanghai) Co. Ltd.
1388 East Kangqiao Road
Pudong, Shanghai 201319
P. 0086 21 3810 8686

TAIWAN
Hardinge Machine Tools
B.V., Taiwan Branch
No.11,Tzu Li 3rd Rd.,
Nantou City, 540 Taiwan
P. 886 49 2260 536
E. cs@hardinge.com.tw

EUROPE

SWITZERLAND
L. Kellenberger & Co. AG
Heiligkreuzstrasse 28
CH 9008 St. Gallen
Switzerland
P. 41 71 2429111
E. info@kellenberger.net

GERMANY
Hardinge GmbH
Fichtenhain A 13c
47807 Krefeld
P. 49 2151 49649 10
E. info@hardinge-gmbh.de

J.G. Weisser Söhne GmbH
Johann-Georg-Weisser-Straße 1
78112 St. Georgen
P. +49 7724 881-0
E. info@weisser-web.com

FRANCE
Jones & Shipman SARL
8 Allée des Ginkgos
BP 112-69672
Bron Cedex, France