

TALENT SERIES

MULTI-FUNCTIONAL CNC LATHE

TALENT 42

TALENT 51



TALENT SERIES

MULTI-FUNCTIONAL CNC LATHE



The Hardinge TALENT® Series machines offer an exceptional combination of features for accuracy, flexibility and durability in a compact design. The unique collet-ready main and sub-spindle design will increase part accuracy and improve surface finish. The TALENT® Series offers two separate base structures, short bed and standard bed lengths, which feature a robust one-piece cast iron base, heavy duty roller linear guideways and ballscrews, with many standard value-added features – thru-tool and headwall coolant, foot switches, chip conveyor interface, and external air hose and gun. The machine features the FANUC OiTF+ control which include many value added features.

FEATURES

- A2-5 I6C collet-ready spindle (TALENT 42)
- A2-6 20C collet-ready spindle (TALENT 51)
- BMT 45 live tooling 12-station with 1/2 Index capability
- Central grease lubrication (manual)
- Foot switch main spindle chuck/collet – open/close
- Foot switch sub-spindle chuck/collet – open/close
- Headwall coolant (main & sub-spindle)
- Bar feed interface
- Chip conveyor interface

AVAILABLE MODELS

TALENT 42 Short Bed
– MY (Milling / Y-axis)

TALENT 42 Standard Bed
– MYT (Milling / Y-axis / Tailstock)
– MSY (Milling / Sub-spindle / Y-axis)

TALENT 51 Short Bed
– MY (Milling / Y-axis)

TALENT 51 Standard Bed
– MYT (Milling / Y-axis / Tailstock)
– MSY (Milling / Sub-spindle / Y-axis)



ROCK DRILL

DIAMETRICAL TOLERANCE ____ .0005" (0.0127MM)

DIAMETER ____ 5.1" (130MM)

FINISH ____ 32 μ IN



KEY FEATURES

COLLET-READY SPINDLE ADVANTAGES

- Collet seats directly in the Hardinge spindle
- Maximum rigidity and gripping power is transferred to the part
- Maximum utilization of RPM
- Minimum weight on spindle
- Minimum overhang from the spindle bearings that assures spindle accuracy is transferred directly to the workpiece
- Optimum T.I.R.
- Gripping force directly over the workpiece
- Superior tolerances and finishes
- Capable of using maximum machine stroke capacity
- Longer tool life
- Quick changeover

LIVE TOOLING

Live tool holders start at 5,000 RPM and are capable of up to 20,000 RPM when purchased with ratios of 2:1 or 4:1 when high speeds are required. The Hardinge BMT live tooling holders provide superior run-out within .00012" (3 micron) making it the overall best in class tooling system.

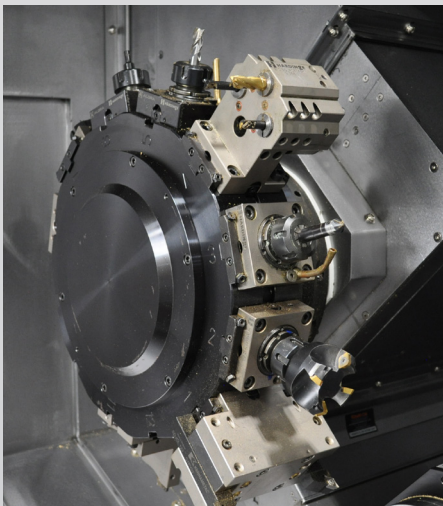

COLLET-READY MAIN SPINDLE

The Hardinge collet-ready spindle is the most versatile machine spindle in the industry – it is uniquely designed to accept both collets and jaw chucks without the use of an adaptor. Because the collet seats directly in the spindle, the workpiece is held close to the spindle bearings which provides the ultimate in accuracy, rigidity and gripping force. It also allows for maximum spindle RPMs which increases productivity. This exclusive design also offers numerous workholding capabilities including solid collets, master collets, dead length collets, step chucks, 3-jaw chucks and FlexC collets systems.

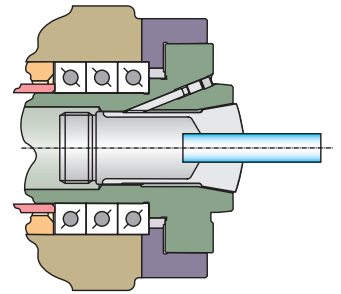

COLLET-READY SUB-SPINDLE

The belt driven sub spindle features a 15Hp (11.5Kw) motor with a speed range of up to 6,000RPM. The A2-5/16C collet-ready spindle allows for the use of a complete assortment of spindle tooling including collets and jaw chucks. It also includes a hydraulic collet-closer and rigid tapping is standard. Please note that step chucks are not compatible on sub-spindle.

HARDINGE CFS SPINDLE

The spindle design is both collet and jaw chuck-ready and does not require a spindle adaptor. Hardinge C Style collets seat directly into the spindle closest to the bearings, so that spindle accuracy is transferred directly to the workpiece. Take advantage of using maximum spindle speeds and feeds, utilizing the maximum working envelope with quick job to job changeover from bar work to chucking, allowing for higher part to part accuracy, better surface finish with longer tool life capability.

Two main spindle configurations to choose from:

- Hardinge A2-5 16C Collet Ready with 42mm thru-spindle capacity
- Hardinge CFS* Global work holding spindle adaptation system with 51mm thru-spindle capacity

* Available on TALENT 51 only

MACHINE CONSTRUCTION

Y-AXIS

Y-axis capability is a huge productivity enhancement on a turn/mill machine tool. To get Y-axis motion, an extra set of ways is used to move the live tool across the face of the spindle. By adding a third linear axis to the turning-center turret it enables rotary cutters to machine across the spindle center line thus greatly expanding the milling capabilities of the machine.

TAILSTOCK

The servo driven tailstock features a non quill style body and is fully programmable with torque control to set the tailstock force, as well as advance or retract between machining cycles. Multiple positioning is possible to allow for multiple bar feed out applications. The system will accommodate either a live or dead center with a #4 Morse taper.

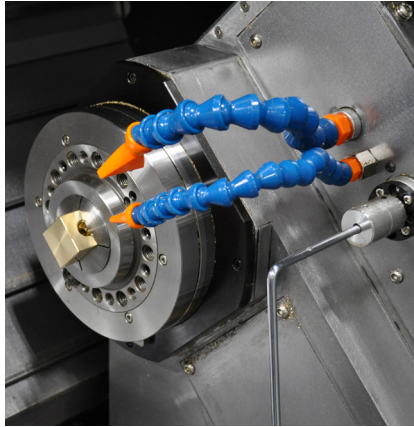

MACHINE BASE

The latest software design platform and FEA (Finite Element Analysis) techniques were used to design and build a rigid, structurally-balanced machine to assure optimum performance and machine life. The FEA software accurately depicts the structural deflection, stress levels, thermal response and vibration response of the assembled components and the assembled machine. Extreme-case loadings are used to verify adverse machining conditions.

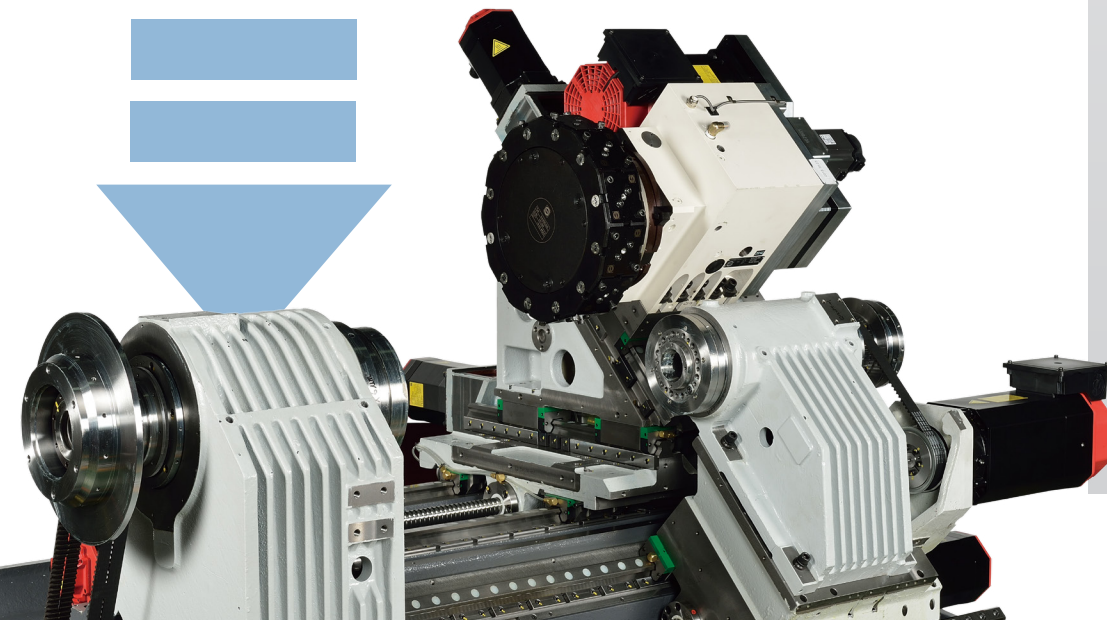

MACHINE OPTIONS

- Central grease lubrication (auto pump lubrication)*
 - Coolant & air management systems
 - Coolant through main & sub-spindle
 - Pressure coolant with max. 1000 PSI
 - Mist collector unit
 - Headwall airblast main & sub-spindle
 - Power transformer
 - Auto door
 - Measurement systems
 - Tool touch probe – Renishaw
 - Component part probe – Renishaw
 - Chip management systems
 - Right side hinge type chip conveyor
 - Right side scraper type chip conveyor
 - Component part handling
 - Parts catcher - main spindle to trap-door
 - Parts catcher – main spindle with parts conveyor
 - Sub-spindle part detection
 - Sub-spindle part ejection
 - Live center, #4 morse taper for tailstock
 - 8 sets of spare M codes
 - BMT 45 16-station live tooling turret (no half index capability)
 - BMT 45 statics tooling package
- * factory order only

POWER & TORQUE CHARTS

TALENT 42

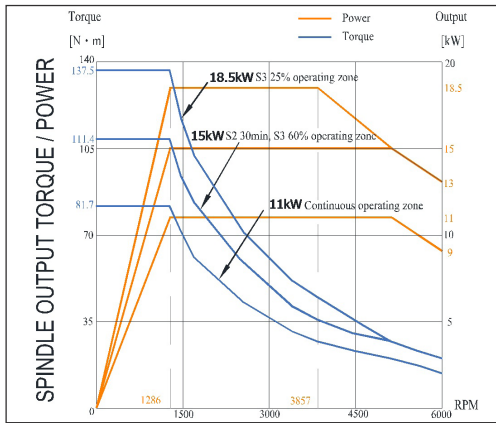

TALENT 51

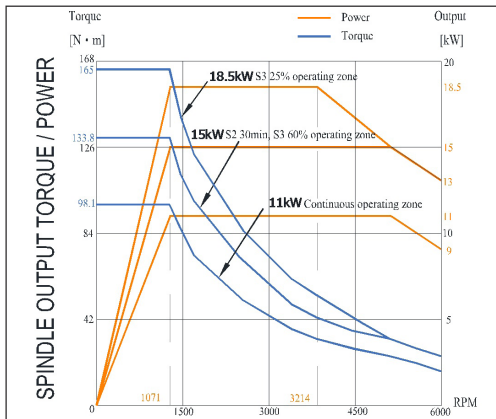

TALENT 42
TALENT 51

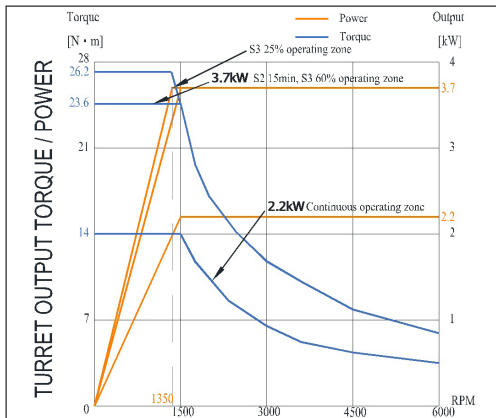

TALENT 42
TALENT 51

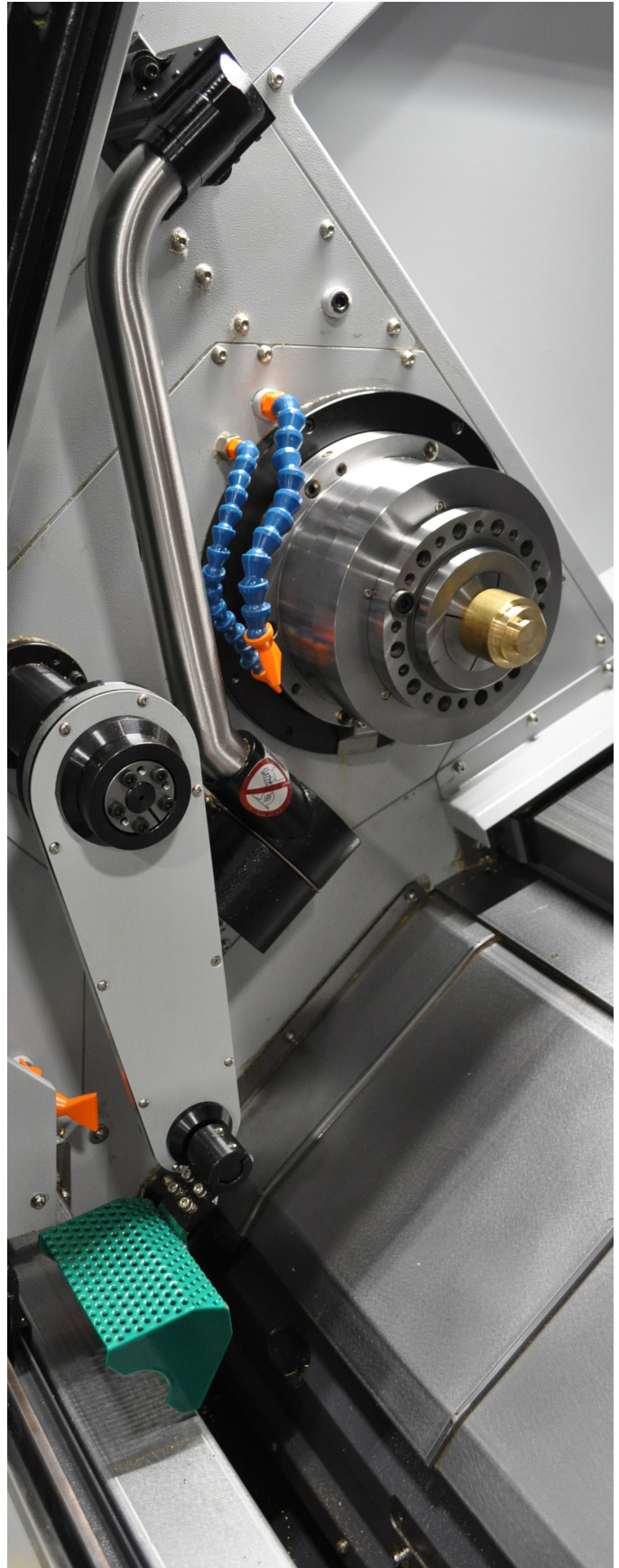
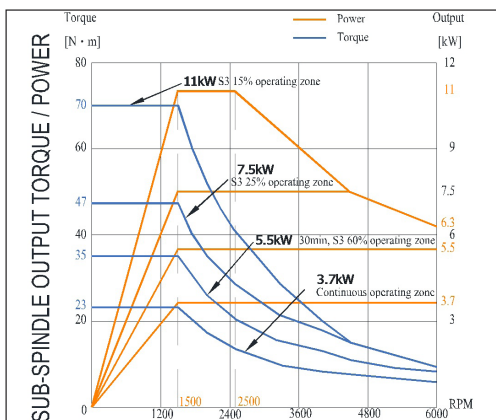

CONTROLS: FANUC OiTF PLUS

PROGRAMMING FUNCTIONS

- Absolute/Incremental Programming
- Additional Custom Macro Variables
- Alarm Display
- Auto Acceleration/Deceleration
- Auto Coordinate System Setting
- Background Editing
- Canned Cycles (Drilling)
- Chamfer/Corner Rounding
- Circular Interpolation by R Programming
- Constant Surface Speed Programming
- Continuous Thread Cutting
- Coordinate System Setting (G50)
- Custom Macro B
- Decimal Point Programming
- Diameter/Radius Programming
- Direct Drawing Dimension Programming
- Display Position, Program, Alarm, History
- Extended Part Program Edit (copy/replace)
- External Workpiece Number Search
- Hardinge Safe Start Format
- Helical Interpolation (for Y-Axis)
- Helical Interpolation (for Non Y-Axis)
- Help Screen
- Input of Offset Values by (G10)
- Interpolation (Linear/Circular)
- MPG Manual Pulse Generator
- Manual Guide i with full color display
- Multiple Repetitive Cycles I (Turning)
- Multiple Repetitive Cycles II (Pocketing)
- Multi Spindle Control
- Program Number Search
- Programmable Parameter Input
- Reference Point Return
- Registered Part Program Storage (1000)
- Rigid Tapping
- Spindle Orient Main & Sub (Std. on Live Tooling Models)
- Spindle Synchronization (Main & Sub)
- Sequence Number Search
- Single Block Operation
- Skip Function G31
- Stored Stroke Check 1, 2 & 3
- Sub Program Call (10 fold nested)
- Thread Cutting Retract
- Thread Cutting
- Tool Life Management
- Tool Nose Radius Compensation (Geometry/Wear)
- Variable Lead Thread Cutting
- Workpiece Coordinate System (G52-G59)
- Standard o Option



FANUC

GENERAL

- Pendant-mounted Full Control
- 10.4" LCD Display
- Graphic Display
- Embedded Ethernet
- RS-232C Communication Ports
- PCMCIA and USB Ports
- Program Resolution .0001" (.001mm)
- Tool Offset Capability .0001" (.001mm)
- Tool Offsets with Geometry/Wear (99)
- Absolute Encoders
- Inch/Metric Selection by G-Code
- Part Program Storage 2MB

MISCELLANEOUS

- Actual Cutting Speed and T-Code Display
- Dual Check Safety
- English
- French/German/Italian/Spanish Language
- Chinese in FANUC menus only
- Full Keyboard
- Ladder Diagram Display
- Polar Coordinate Interpolation
- Cylindrical Interpolation

*North American standard. Siemens available

Conversational programming features offered on the CNC control is the CNC control builder's standard product, which may not fully support all machine functions. It is recommended the end user reference the control system documentation, or contact the control manufacturer, for further details of use or customization.

FLOOR PLAN

TALENT Standard Bed

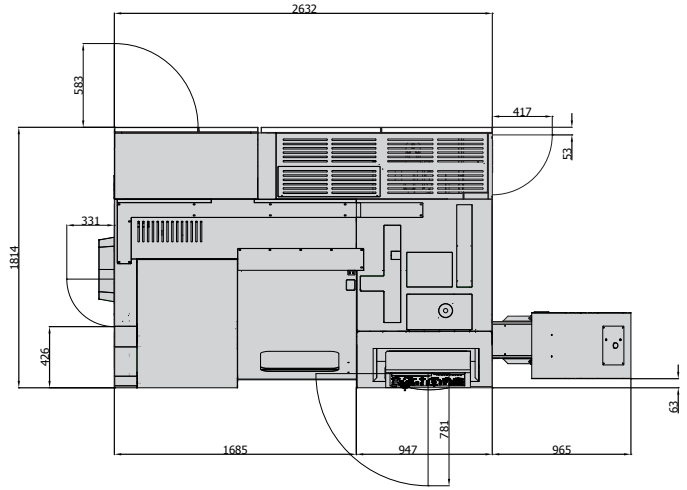
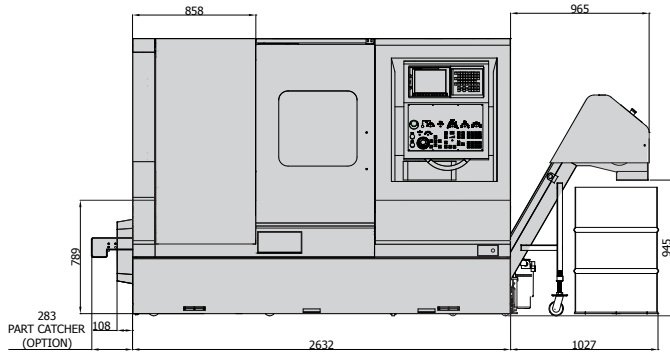

FRONT VIEW

TOP VIEW

TALENT Short Bed

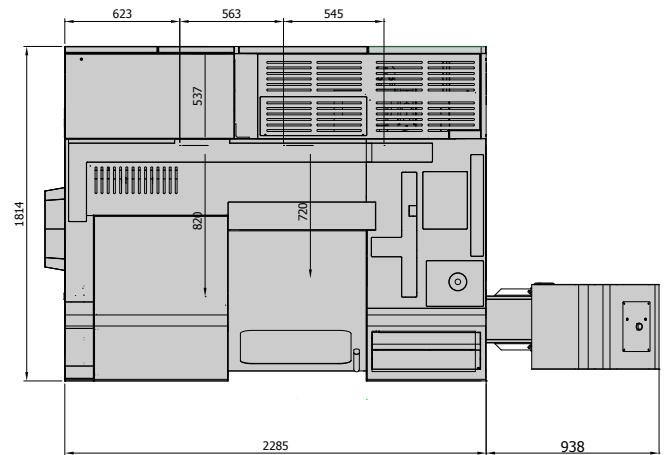
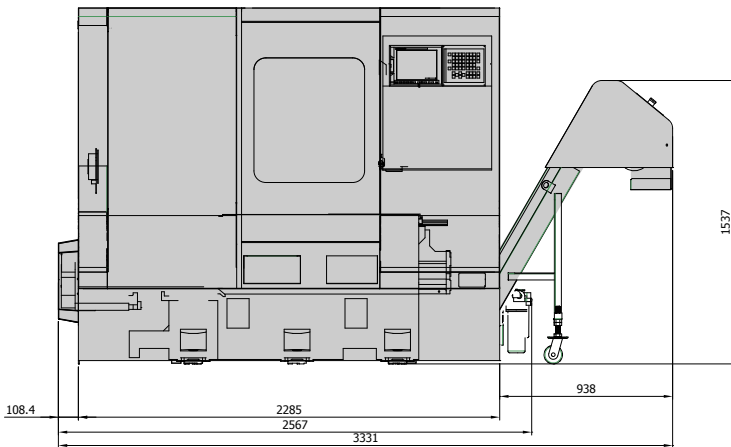

SPECIFICATIONS

	TALENT® 42 MY		MYT, MSY		TALENT® 51 MY		MYT, MSY	
MAIN SPINDLE	Short Bed		Standard Bed		Short Bed		Standard Bed	
Collet Ready Spindle Config - ANSI	A2-5 / 16C				CFS/A2-6 / 20C			
Draw Tube Type	Hydraulic				Hydraulic			
Through Draw Tube Capacity	1.65" (42mm)				2" (51mm)			
Gripping Capacity with Step Chuck & Closer	6" (152mm)				8" (203mm)			
Maximum Swing Over Way Cover	21.65" (550mm)				21.65" (550mm)			
12-station max. turning diameter BMT45	11.41" (290mm)				11.41" (290mm)			
16-station max. turning diameter BMT45	9.44" (240mm)				9.44" (240mm)			
Turning Length - max (without chuck)	13.16" (334.5mm)		23.4" (594.5mm)		13.16" (334.5mm)		23.4" (594.5mm)	
Turning Length - max (with chuck)	8.61" (218.9mm)		18.85" (478.9mm)		8.12" (206.3mm)		18.35" (466.2mm)	
Max. Speed (1 rpm Steps)	6000 rpm				5000 rpm			
Base Speed	1286 rpm				1071 rpm			
Continuous Power Rating	14.75HP (11 kW)				14.75HP (11 kW)			
Maximum Power Rating	24.80HP (18.5 kW)				24.80HP (18.5 kW)			
Continuous Torque Rating	81.6 Nm (60.24 ft.lb.)				98.1 Nm (72.31 ft.lb.)			
Maximum Torque Rating	137.3 Nm (101.32 ft.lb.)				165 Nm (121.7 ft.lb.)			
SUB-SPINDLE								
Collet Ready Spindle Configuration	A2-5 / 16C				A2-5 / 16C			
Draw Tube Type	Hydraulic				Hydraulic			
Through Draw Tube Capacity	1.65" (42 mm)				1.65" (42 mm)			
Gripping Capacity with Chuck	5.5" (130 mm)				5.5" (130 mm)			
Max. Speed (1 rpm Steps)	6000 rpm				6000 rpm			
Base Speed	1500 rpm				1500 rpm			
Continuous Power Rating	5HP (3.7 Kw)				5HP (3.7 Kw)			
Maximum Power Rating	15HP (11 Kw)				15HP (11 Kw)			
Continuous Torque Rating	23.5 Nm (17.3 ft.lb.)				23.5 Nm (17.3 ft.lb.)			
Maximum Torque Rating	70 Nm (51.62 ft.lb.)				70 Nm (51.62 ft.lb.)			
TURRET CONFIGURATIONS								
12 Station with ½ Index Capability	BMT 45/ DIN 1809				BMT 45/ DIN 1809			
Drive Configuration (opt. 16 Station)	BMT 45/ DIN 1809				BMT 45/ DIN 1809			
LIVE TOOLING DRIVE SYSTEM								
Max. Speed (1 rpm Steps)	5000 rpm				5000 rpm			
Maximum Power Rating	5HP (3.7 Kw)				5HP (3.7 Kw)			
Maximum Torque Rating	26.1 Nm (19.3 ft.lb.)				26.1 Nm (19.3 ft.lb.)			
TRAVELS AND FEED RATES								
X Axis Travel Max - Live Tooling (BMT)	7.08" (180mm)				7.08" (180mm)			
Z Axis Travel Max	15.43" (392mm)		25.67" (652mm)		15.43" (392mm)		25.67" (652mm)	
Y Axis Travel Max	1.65" (+/- 42mm)				1.65" (+/- 42mm)			
X and Z Axis Rapid Traverse Rates	30 m/min (1181 ipm)				30 m/min (1181 ipm)			
Y Axis Rapid Traverse Rates	10 m/min (394 ipm)				10 m/min (394 ipm)			
MACHINE ACCURACY								
Evaluation Standard	ISO 230-2				ISO 230-2			
Repeatability - X & Z Axes (ISO)	0.000197" (0.005mm)				0.000197" (0.005mm)			
MACHINE DIMENSIONS								
Length	101.1" (2567mm)		114.7" (2914mm)		101.1" (2567mm)		114.7" (2914mm)	
Depth	71.42" (1814mm)		72.2" (1834mm)		71.42" (1814mm)		72.2" (1834mm)	
Height	76.1" (1932mm)				76.1" (1932mm)			
Weight	10,802 lbs (4900 kg)		12,786lbs (5800 kg)		10,802 lbs (4900 kg)		12,786lbs (5800 kg)	
Power Requirements volts/amps/phase	220V/67 FLA/ 3 phase							
Air Requirements	70-90 PSI (4.8-6.2 bar)							

WORKHOLDING FLEXIBILITY

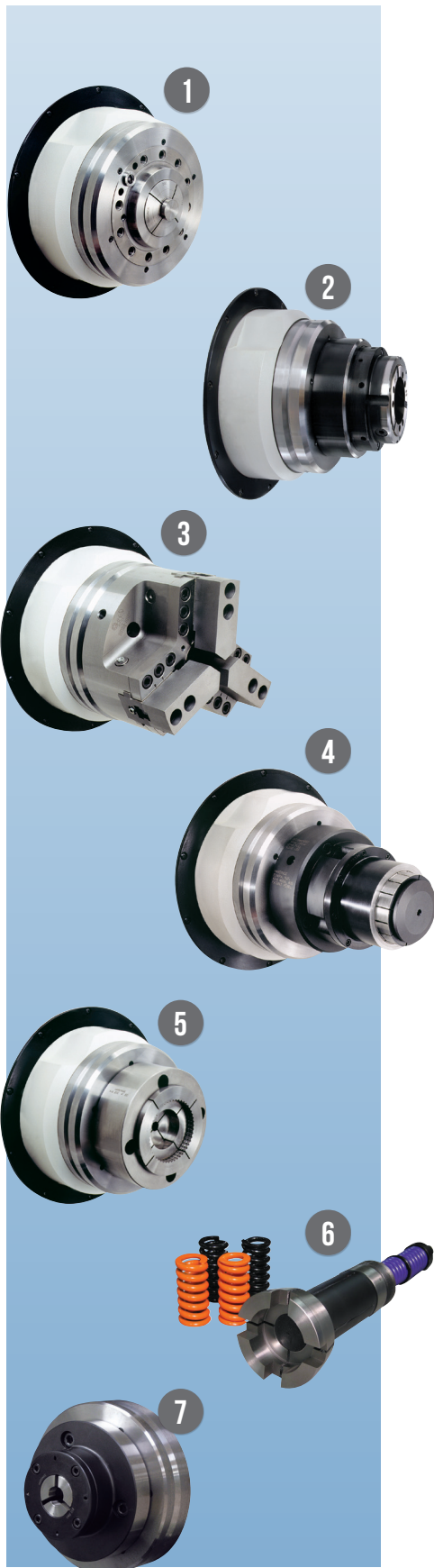

UNLIMITED FLEXIBLE WORKHOLDING OPTIONS

Hardinge is unique as a machine tool builder — we manufacture our own workholding products. Precision and accuracy is yours when you use Hardinge perfectly-mated workholding products.

1 COLLETS

Hardinge hardened and ground collets are inspected and measured in a Hardinge SUPER-PRECISION® spindle. Collets are available in fractional round, hex and square sizes and round metric, as well as round serrated fractional and metric sizes. Use adjustable, machinable collet stops for accurate part positioning.

EMERGENCY COLLETS

Emergency collets have a soft face with a pilot hole for customer drilling, boring and stepping out to the exact size required. An optional extended nose permits deeper counterbores when required and tool clearance for extended work.

2 FLEX™ QUICK-CHANGE VULCANIZED COLLET SYSTEMS

Interchangeable quick-change vulcanized collet heads have a working range of $\pm .020$ " (0.5mm) to accept bar stock variation. Collets change in seconds, while accuracy is maintained at $.0004$ " (.010mm).

STYLE "S" MASTER COLLETS AND PADS

pads can be changed much quicker than solid collets can. Pads cost less and use less storage space when compared to a standard solid collet. Choose from hardened and ground, semi-hard and emergency pads. Styles S16, S20 and S26 require a collet closer.

3 3-JAW POWER CHUCKS

Hardinge power chucks are lever operated, counter-centrifugal and dynamically balanced. Quick-change chucks are also available.

4 SURE-GRIP® EXPANDING COLLET SYSTEMS

The Hardinge Sure-Grip expanding collet provides high-precision, internal gripping solutions with true parallel gripping. Collet-style and spindle-mount styles are available, depending on the machine model.

Master Expanding Collets are a lower-cost alternative to Sure-Grip Expanding Collet Systems and include a dead-length feature.

5 STEP CHUCKS AND CLOSERS*

Step Chucks and closers are used to accurately hold larger diameter parts. * Main spindle only

6 FORCE-LIMITING STEP CHUCK

The Hardinge force-limiting step chuck has built-in force control to safely grip thin-wall parts. Maintain inside and outside concentricity in a fail-safe process while eliminating the nuisance of manually tweaking the draw bar.

7 DEAD-LENGTH® SYSTEMS

Maintain part-length control by using Hardinge dead-length systems. Choose from dead-length collet assemblies, thru-hole collets, step chucks and spider-stop step chucks. 16C to #22 B&S adapter shown on A2-5 sub-spindle.

RING GEAR

ROUNDNESS .0005" (0.0127MM)
DIAMETER 6.88" (175MM)
FINISH 16 μIN

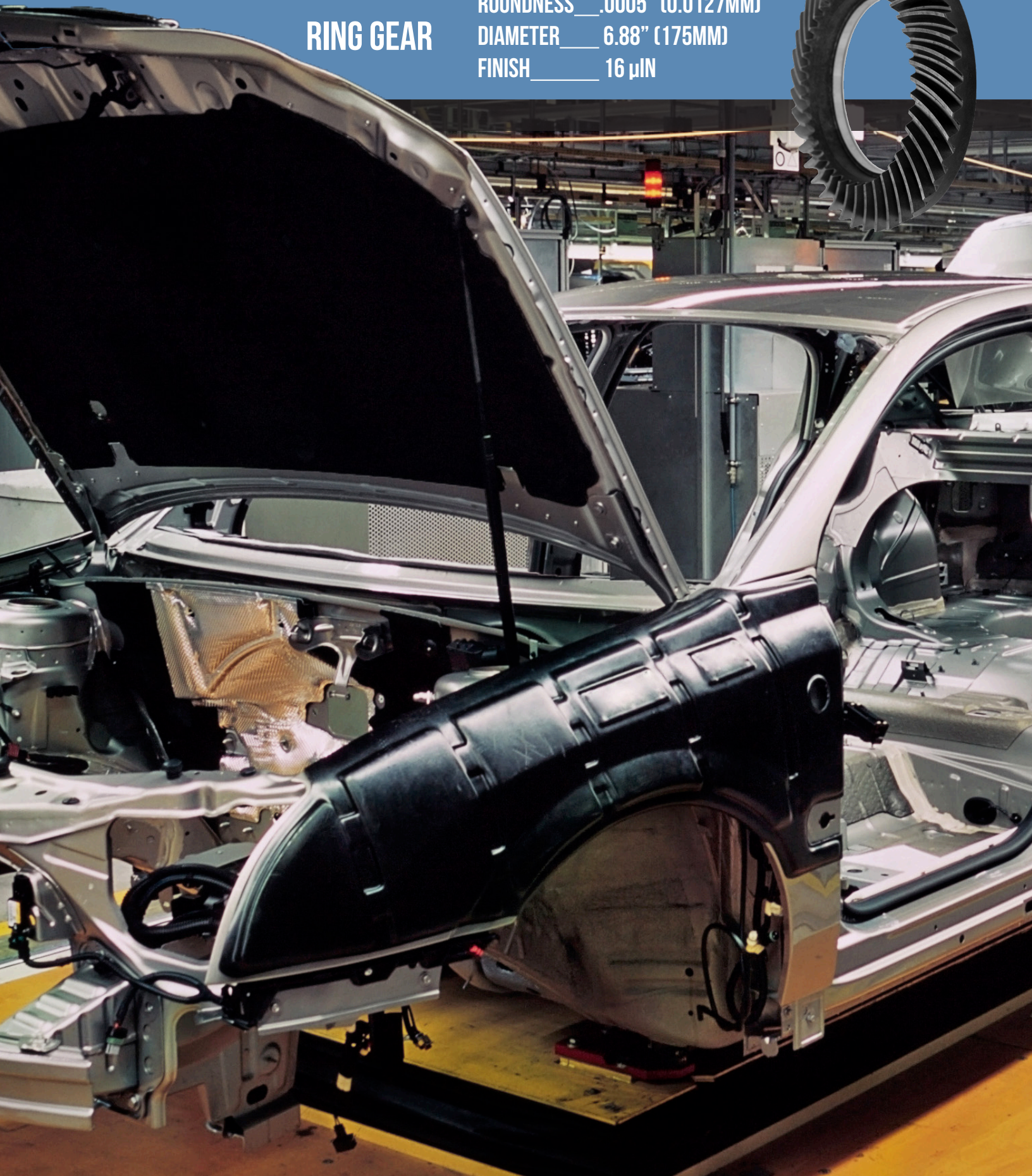

HARDINGE WORLDWIDE

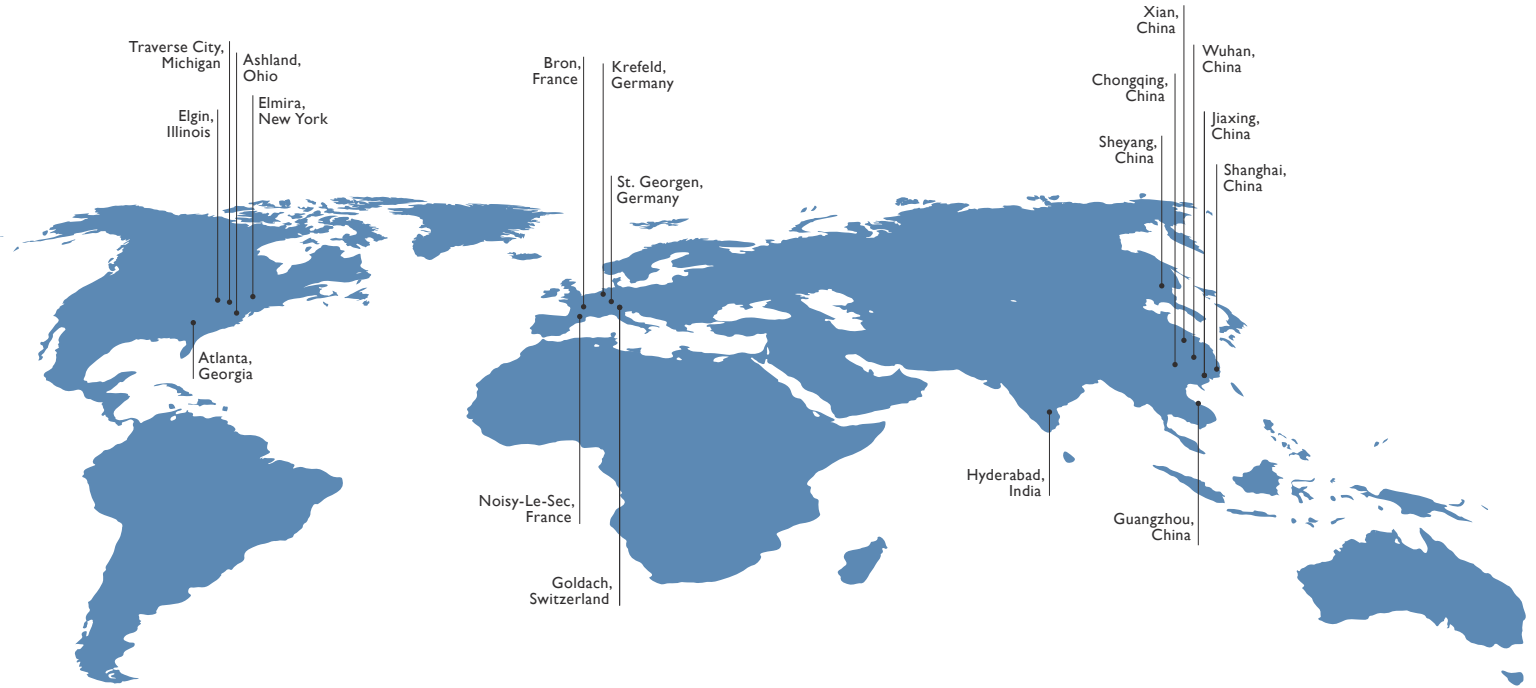

Hardinge is a leading international provider of advanced metal-cutting solutions. We provide a full spectrum of highly reliable CNC turning, grinding, and honing machines as well as technologically advanced workholding accessories.

The diverse products we offer enable us to support a variety of market applications in industries including aerospace, agricultural, automotive, construction, consumer products, defense, energy, medical, technology, transportation and more.

We've developed a strong global presence with manufacturing operations in North America, Europe, and Asia. Hardinge applies its engineering and applications expertise to provide your company with the right machine tool solution and support every time.

AMERICAS

GEORGIA
Hardinge Corporate
79 W Paces Ferry Rd, 2F
Atlanta, GA 30305
P. 800.843.8801

ILLINOIS
Hardinge
1755 Britannia Dr
Unit 1A
Elgin, IL 60124

MICHIGAN
Forkardt
2155 Traversefield Dr
Traverse City, MI 49686
P. 800.544.3823
E. tcsales@forkardt.com

NEW YORK
Hardinge
1 Hardinge Drive
Elmira, NY 14903
P. 800.843.8801
E. info@hardinge.com

OHIO
Ohio Tool Works
1374 Enterprise Parkway (TR 743)
Ashland, OH 44805
P. 419.281.3700
E. sales@ohiotoolworks.com

EUROPE

SWITZERLAND
Hardinge Kellenberger AG
Thannäckerstrasse 22
CH-9403 Goldach
P. 41 71 2429111
E. info@kellenberger.net

GERMANY
Hardinge GmbH
Fichtenhain A 13c
47807 Krefeld
P. 49 2151 49649 10
E. info@hardinge-gmbh.de

J.G. Weisser Söhne GmbH
Johann-Georg-Weisser-Straße 1
78112 St. Georgen
P. +49 7724 881-0
E. info@weisser-web.com

FRANCE
Jones & Shipman SARL
8 Allee des Ginkgos
BP 112-69672
Bron Cedex, France

ASIA

CHINA
Hardinge Machine
(Shanghai) Co. Ltd.
1388 East Kangqiao Road
Pudong, Shanghai 201319
P. 0086 21 3810 8686