

TALENT TT SERIES

Twin Spindle/Twin Turret
Multi-Tasking Turning Center

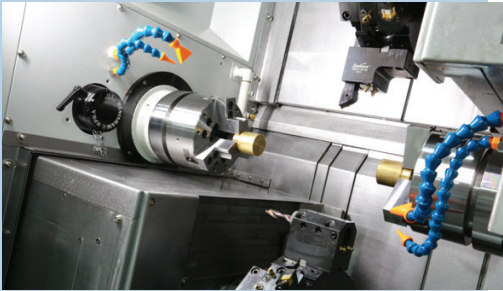

TALENT TT SERIES



1

MULTI-AXIS MACHINING OPERATIONS

- 8 Axes for demanding production requirements
- Finish parts complete on a single machine in a single operation
- Reduced cycle times
- Enhanced features for superior performance
- Full Y axis capability on upper turret



2

TWIN SPINDLES WITH C AXIS CAPABILITIES

- Powerful 15Hp main and secondary spindles
- Exact part roundness, superior tolerance holding and part finishes
- Exact synchronization for part transfers
- Full C Axis contouring on both spindles



3

TWIN TURRETS WITH LIVE TOOLING CAPABILITIES

- Twin 16 stations turrets
- All stations are live capable
- Industry standard BMT45 DIN 1809 tooling system
- Simultaneous machining for reduced cycle times
- One or both turrets can work on either spindle without limitations



4

HEAVY DUTY CONSTRUCTION

- Highly rigid cast iron base
- Designed with FEA design analysis
- Modular construction
- Heavy duty ballscrews and linear guideways for maximum machine stiffness and overall machining consistency

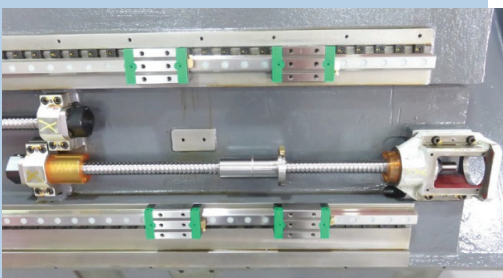

TWIN SPINDLE/TWIN TURRET MULTI-TASKING TURNING CENTER

THE CYCLE TIME REDUCER! GO FROM RAW MATERIAL TO FINISHED PARTS IN ONE MACHINE... ELIMINATE SECONDARY OPERATIONS.

Obtain optimum throughput for your production facility or job shop. The Talent TT Series machines provide ultimate flexibility, capability, functionality and maximum productivity all with minimal operator intervention. The machine is configured with 8 axis for the most demanding production requirements. Either turret is capable of working on either spindle, independently or simultaneously, without limitations for maximum part processing flexibility to reduce cycle times. Additionally, should the need arise either the secondary spindle or the lower turret can be used as a tailstock for added functionality.



KEY ADVANTAGES AND FEATURES OF UTILIZING A TWIN SPINDLE/TWIN TURRET MULTI-TASKING TURNING CENTER

- Finish parts complete in one machine – less parts handling
- Reduced cycle times – two tools in the cut simultaneously
- Reduced work in process
- Reduced lead time for lean manufacturing and JIT delivery
- High volume production – long run batches or dedicated production of simple to complex components
- Wide range of process applications
- Easier processing of part families and less setups due to the large number of available tool stations and configurations
- Reduced setup time with the use of BMT industry standard tooling with very high repeatability
- Compact design requires less floor space than most competitors in its class
- Reduced labor costs – one operator can run multiple machines
- Full Y axis capability on upper turret

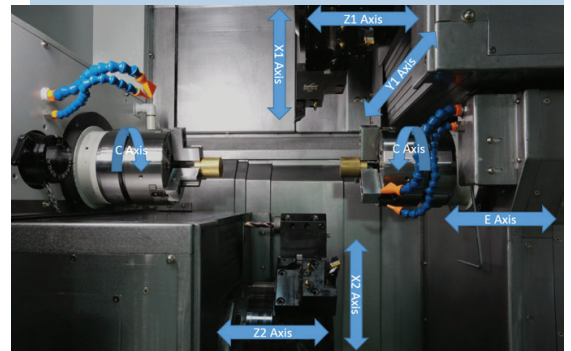
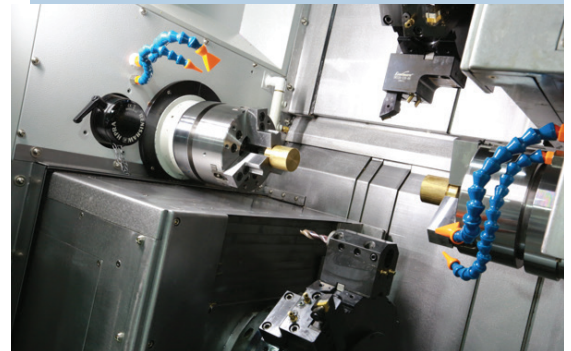

EXCLUSIVE FEATURES

- Both turrets can work on either or both spindles simultaneously
- Hand scrapped structural joints to increase contact
- Heavy duty linear guideways and ball screws
- Wide variety of spindle tooling is available

Sample machining arrangements.

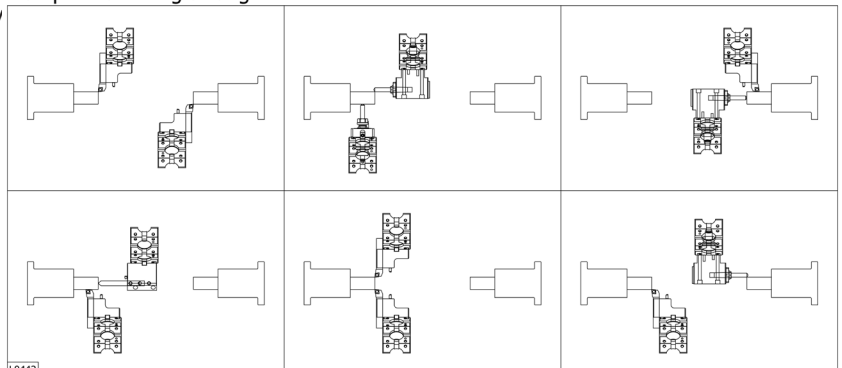

TALENT TT SERIES

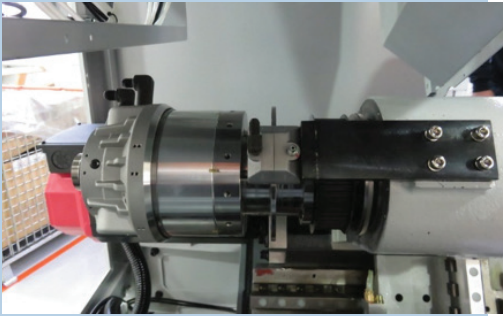

TWIN SPINDLES WITH C-AXIS CONTOURING

- High strength, ductile cast iron headstock housings are hand scraped to the base for optimum stiffness, rigidity and vibration dampening
- Secondary spindle clamps the transferred workpiece for subsequent operations, can also be used as a tailstock with programmable torque control
- Large 3.54"/90mm front bearing bore provided excellent static and dynamic stiffness
- Low-inertia hydraulic disk brakes provide superior clamping power for live tooling operations
- Adjustable Hydraulic actuators for use with collets and jaw chucks
- Spindle bearings are protected with air purge and labyrinth seal systems
- Exact part roundness and surface finish capabilities



TALENT TT42 Spindle 6000RPM Output Diagram

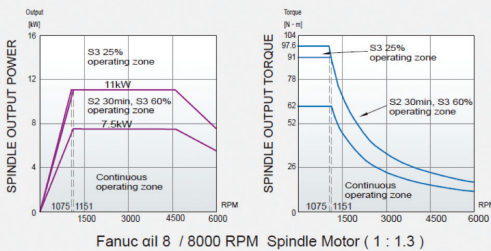

Fanuc oil 8 / 8000 RPM Spindle Motor (1 : 1.3)

TALENT TT51 Spindle 5000RPM Output Diagram

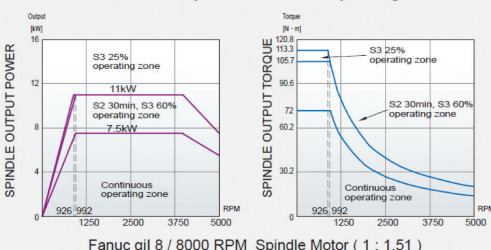

Fanuc oil 8 / 8000 RPM Spindle Motor (1 : 1.51)

- Less than 1 μ
- Less than .8 μ Ra
- Twin precision spindles with ANSI A2-5" (TT42) or A2-6" (TT51) models and A2-5" on the secondary spindle
- Powerful spindle drive packages
 - 15Hp (11Kw) on TT42 and TT51
- Up to 6,000 -rpm (TT42) and 5,000-rpm (TT51) speed range on both spindles allow exact synchronization for part transfers
- High torque ratings
 - 68ft-lbs (91Nm) on TT42
 - 78 ft-lbs (105Nm) on TT51
- A single timing style drive belt is used for power transmission from the spindle motor to the spindle
- Accurate part transfer – within .0005"(.012mm) between spindles
- C axis contouring with .001° degree positioning on both spindles for live tooling applications
- Large availability of spindle tooling from Hardinge, the world leader in work holding
 - Flex C systems
 - Collets and collet adaption chucks
 - Expanding collet systems
 - 3 jaw chuck systems



TWIN SPINDLE/TWIN TURRET MULTI-TASKING TURNING CENTER

TWIN TURRETS WITH LIVE TOOLING CAPABILITY

- Twin 16 station turrets can be used on either spindle or both spindles simultaneously. Every turret station is live capable
- High-speed bidirectional indexing (.69 second station to station) keeps non-cut time to a minimum
- Rigid turrets accurately lock into place within .000050" (.12 μ)
- Easier processing of parts families and fewer setups due to large number of tooling stations
- Industry standard BMT-45 DIN 1809 peripheral mounted tooling system
- Multiple tools can be mounted on a single station to increase tool capacity
- Wide range of optional BMT-45 tool holders are available from Hardinge featuring coolant nozzles or thru-tool coolant capabilities
- Powerful live tooling capability on all stations for radial and axial milling/drilling operations
 - 7.5Hp (5.5Kw) power rating
 - 17.5ft-lbs (23.8Nm) torque rating
 - 5000-rpm maximum speed
 - Optional Live tooling attachments up to 20,000-rpm
- Standard Y axis on the top turret with helical interpolation function
- Rigid tapping capability, all spindles is standard
- Angular workpiece machining is easily accomplished using angular adjustable BMT-45 DIN 1809 live tooling attachments
- Digitally-controlled servo motors on all axes are superior for positioning accuracy and stiffness
- Fast rapid traverse rates on all axes provide for reduced non-cut time
 - 24m/min on X, X2 and Y axes
 - 40m/min on Z, Z2 and secondary spindle axes
- Powerful 3.6Hp (2.78Kw) axis drive motors

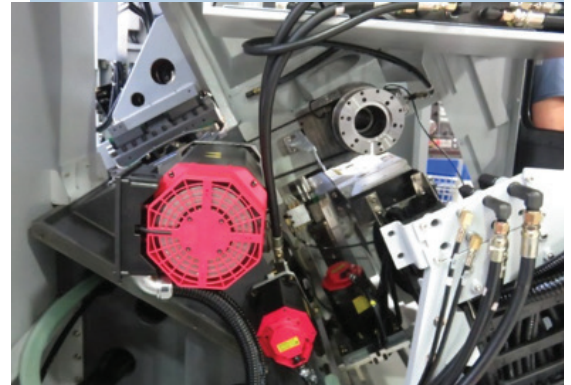

TALENT TT SERIES

RIGID MACHINE BASE AND HEAVY-DUTY CONSTRUCTION

IMPRESSIVE 16,534LB (7500KG) MACHINE WEIGHT

The design of the machine allows convenient placement in any shop while offering a wide range of functionality and capability

MACHINE BASE

Heavy ribbed cast iron base with 60° slant bed offers excellent rigidity and vibration damping capabilities. 6 leveling feet (3 fixed and 3 adjustable) are supplied to support the machine base on the shop floor, there are additional support feet under the electrical cabinet to assist in supporting that structure.

60-DEGREE SLANT BED

Allows efficient chip removal. Use of water or oil based coolant is allowed.

FEA (FINITE ELEMENT ANALYSIS)

Techniques are used to design and build a more rigid, structurally-balanced machine to assure optimum fatigue life. Unique CAD software accurately depicts the structural deflection, stress levels, thermal response and vibration response of the assembled components and the assembled machine. The most extreme case loadings are used to test adverse machining conditions.

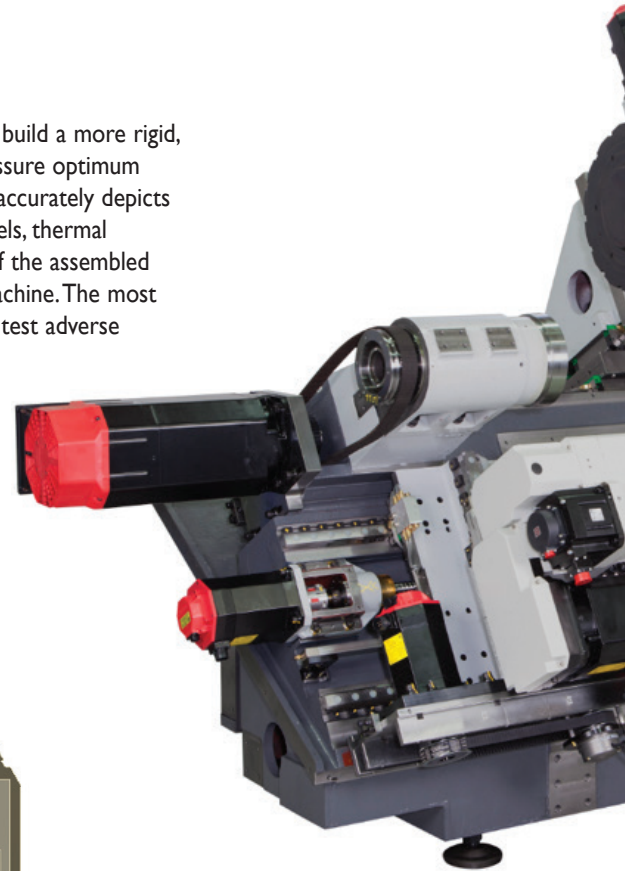
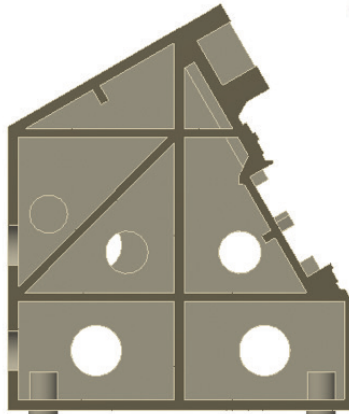

OPTIONS TO SUIT ANY MACHINING REQUIREMENT

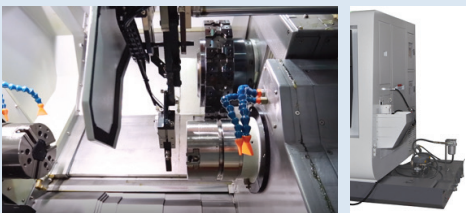

PARTS REMOVAL SYSTEM (CONVEYOR-TYPE)

- Gripper type system include which is extended in the machine envelope to remove parts from spindle two
- Conveyor is located outside the machining envelop to minimize chip and coolant contamination
- Finished work pieces are conveniently removed from the right end of the machine without interrupting machine cycle.

PARTS REMOVAL SYSTEM (THROUGH SECONDARY SPINDLE)

- Finished workpieces remain in the secondary spindle after cutoff
- Workpieces are pushed through the spindle by each succeeding cut off workpiece onto a guide channel that extends outside the machine enclosure

LIVE TOOLING ATTACHMENTS

- Fast job turnaround (JIT)
- Use up to 16 cross and/or end-working attachments on each turret for drilling, milling and tapping operations
- Attachments permanently lubricated
- Speeds fully programmable clockwise or counter clockwise in 1-rpm increments
- 1-degree spindle orient included

TWIN SPINDLE/TWIN TURRET MULTI-TASKING TURNING CENTER

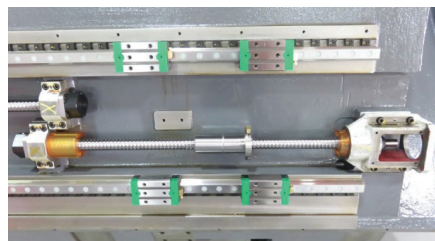
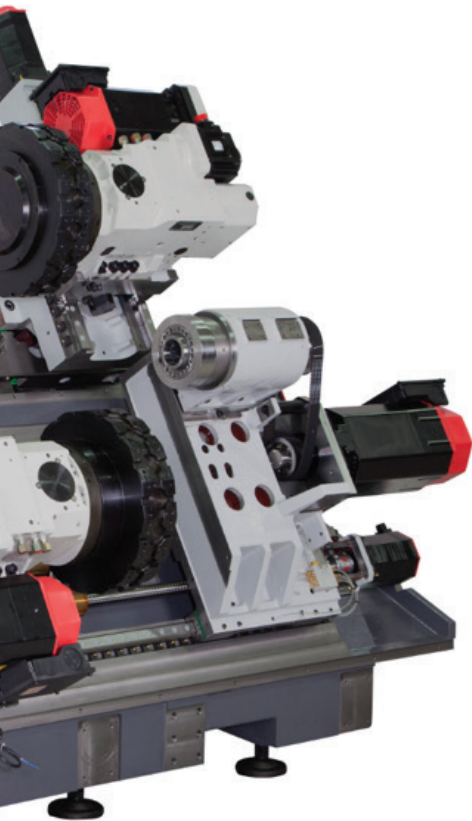

OVERSIZED WIDE SET HEAVY DUTY LINEAR GUIDEWAYS

Standard on all axes for extra heavy loading. Separate rail systems are provided for the upper and lower turrets, carriage and secondary spindle. Linear ways produce minimal friction for:

- Low heat and thermal growth
- Maximum static and dynamic stiffness
- Overall machining consistency
- Reduce cycle times
- Longer machine life

HEAVY DUTY 1.259" (32MM) DIAMETER BALL SCREWS

Oversize bearings and bearing supports are used on all machine axis and provide low stress, high static and dynamic stiffness, and long fatigue life. The double-nut ball screws are preloaded for maximum rigidity against thrust load. Ball screw mounts are recessed inside castings, providing minimal overhang and reduced torsional loads to the linear guides. Ball screws and linear guides are completely protected by telescoping steel covers.

AUTOMATIC GREASE LUBRICATION SYSTEM

Used on all linear guides, ball screws and truck bearings — coolant contamination is virtually eliminated for improved coolant life. An operator prompt is displayed at the appropriate interval on the control.



TOOL TOUCH-OFF SYSTEM

- Reduces tool setup time
- Two separate probes — one for each turret
- Four direction probe surfaces
- Audible and visual signals on probe contact
- No N/C programming involved in setup
- Detachable probe arm for convenient storage



PART PRESENT DETECTOR (SECONDARY SPINDLE)

- Provided automatic detection of machine workpiece in the spindle
- Machine automatically shuts down during unmanned operations if part is not present

CHIP CONVEYOR

- Side discharge
- Automatic removal of chips from the machining area — reduced downtime for cleaning and maintenance
- Variable speed motor
- Ideal for unmanned operations

Y AXIS (UPPER TURRET ONLY)

- Provides precise, complex off-center milling and drilling operations

SPINDLE TOOLING

- Flex C collet system
- Collet Adaptation chucks available for a variety of collet type systems (16C/20C/B Style)
- 3 Jaw chuck systems
- Sure Grip expanding collets
- Dead length systems

THRU-SPINDLE AIR BLAST (SECONDARY SPINDLE)

- Automatic removal of chips from the workholding device for cleaner gripping surface

THRU-SPINDLE COOLANT (MAIN OR SECONDARY SPINDLE — NOT BOTH)

- Coolant is fed through the spindle from the coolant system to flush chips from spindle and gripping surfaces
- Lower cycle times/better production rates

ADDITIONAL EQUIPMENT AVAILABLE

- Auto Door
- Coolant Chiller
- Bar Feed Systems
- Power Transformers
- Stack Light

TALENT TT SERIES

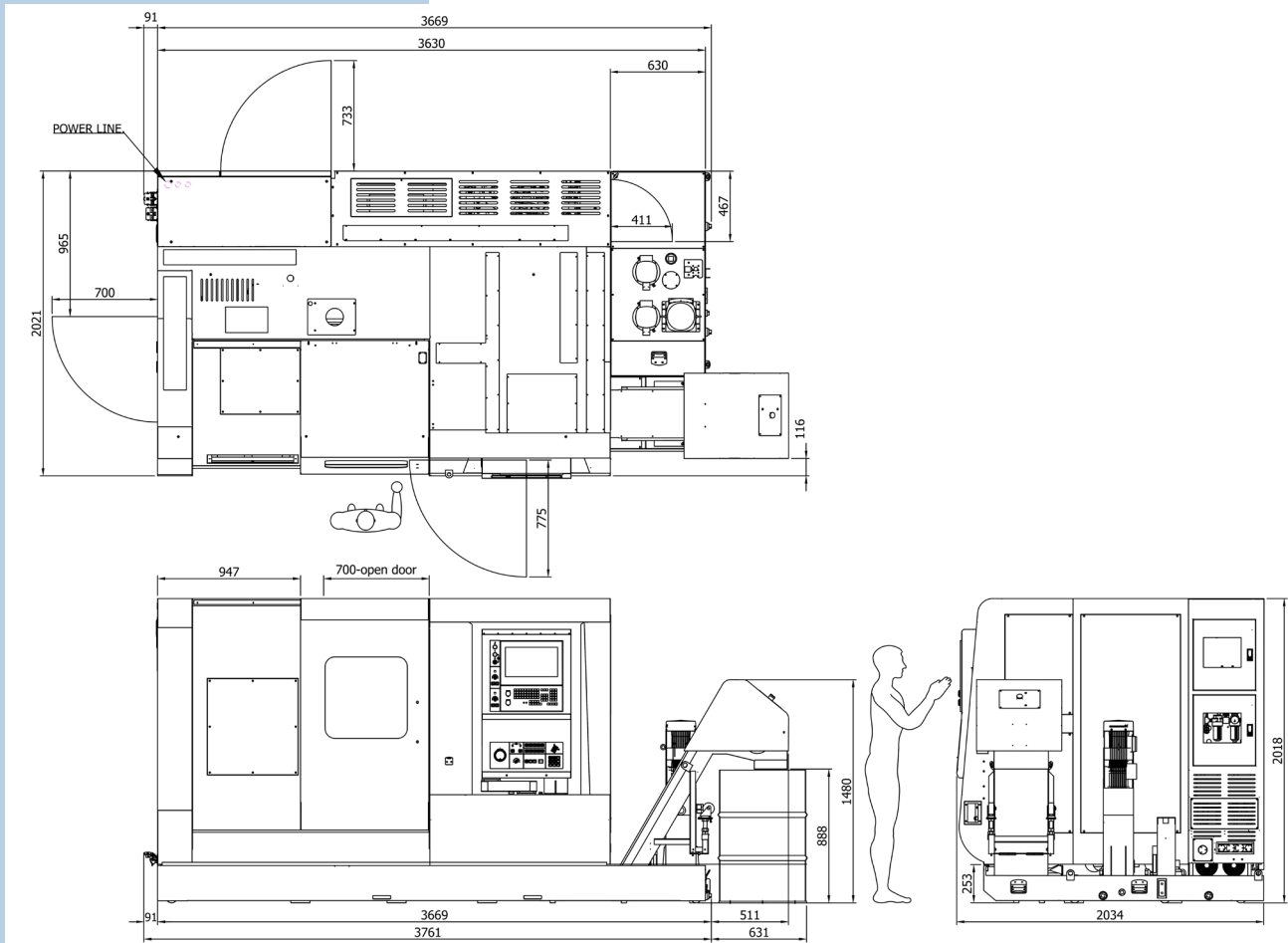

TWIN SPINDLE/TWIN TURRET MULTI-TASKING TURNING CENTER

TALENT TT42 /TT51 WORKING ENVELOPE

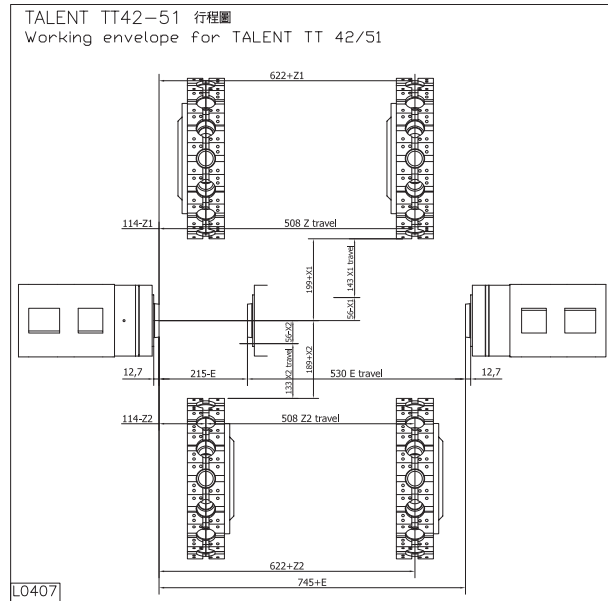

UPPER TURRET

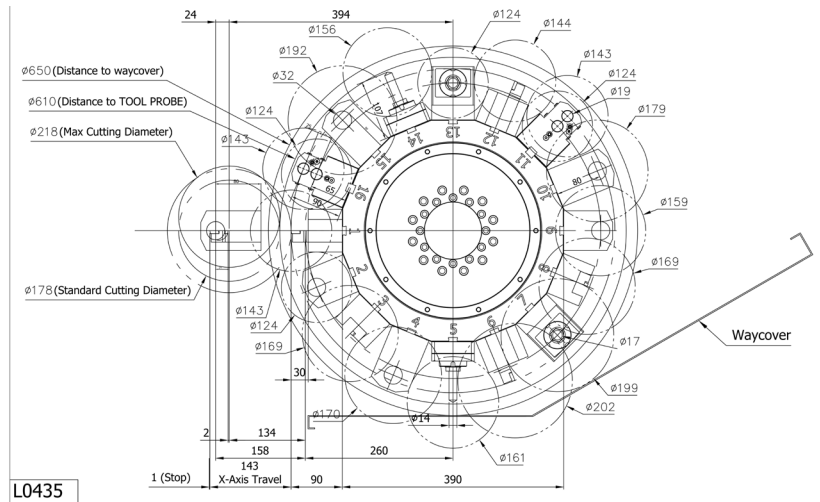

LOWER TURRET

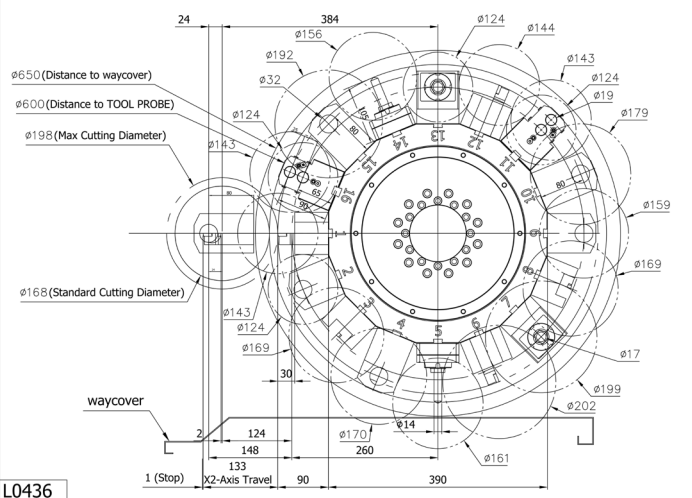

TALENT TT SERIES



FANUC OiTF DUAL-PATH SPLIT SCREEN CONTROL

The Hardinge TT Series of multi-tasking turning centers features a custom designed CNC with dual processing power, speed and ease of operation to get the most out of your turning center!

Experienced CNC users will appreciate fast machining cycles with the OiTF controls powerful 64 Bit dual processing capabilities.

Program both the main and secondary spindles for simultaneous machining — synchronized spindles assure smooth part transfer. C-Axis and spindle orient on both spindles accommodate complex machining. Synchronization of the tapping axis and spindle rotation allows the use of rigidly-mounted taps.

A split-screen 15" LCD display is helpful during setup for viewing of positions, distances-to-go, and programs all on a single screen. The background programming feature allows you to load the next program "off-line" while the machine is busily producing parts.

A simulated, graphic toolpath display verifies correctness of each step of the operator's program.

Full complement of standard features for maximum performance — very few options needed!

General	
Two Pair of Interpolating Axes	Standard
Inch/Metric Selection by G-Code	Standard
Programmable Resolution .001"/.001mm	Standard
Tool Offset Capability .001"/.001mm	Standard
160 Meters Part Program Storage	Standard
Part Program Storage (320, 640 or 1,280 Meters Total)	Optional
Data Input/Output	
MDI (Manual Data Input) Operation	Standard
Reader/Punch Interface (RS-232 Software/Hardware)	Standard
Programming Functions	
Auto Coordinate Setting	Standard
Axis Recomposition	Standard
Background Editing	Standard
Balanced Cutting	Standard
Canned Cycles (Drilling)	Standard
Chamfer/Corner Rounding	Standard
Constant Surface Speed Programming	Standard
Continual Thread Cutting	Standard
Coordinate System Setting (G50)	Standard
Custom Macro B	Standard
Decimal Point Programming	Standard
Diameter Programming	Standard
Direct Drawing Dimension Programming	Standard

Programming Functions (cont'd)	
Exact Stop	Standard
Expanded Stored Stroke Check	Standard
Extended Part Program Edit	Standard
Graphic Tool Path Display	Standard
Helical Interpolation	Standard
Input of Offset Value by Programming (G10)	Standard
Multiple Repetitive Canned Cycles I (Turning)	Standard
Multiple Repetitive Canned Cycles II (Pockets)	Standard
Option Stop	Standard
Program Number Search	Standard
Reference Point Return	Standard
Registered Programs (63)	Standard
Registered Part Program Numbers (125, 200 or 400 Total)	Optional
Rigid Tapping	Standard
Single Block Operation	Standard
Spindle Synchronization	Standard
Stored Stroke Check	Standard
Thread Cutting	Standard
Thread Cutting Cycle Retract	Standard
Tool Life Management	Standard
Tool Nose Compensation	Standard
Polygon Turning	Standard
Tool Post Interference Check	Standard
Variable Lead Thread Cutting	Standard

Operation	
Dry Run	Standard
Dwell Time	Standard
Emergency Stop	Standard
Machine Lock	Standard
Manual Feedrate Override (0 to 150%)	Standard
Manual Pulse Generator	Standard
Manual Rapid Traverse Override (Low-25-50-100%)	Standard
Tool Geometry and Tool Wear Offsets (99 Pair Each)	Standard
Miscellaneous	
Actual Feed Display	Standard
C-Axis on Both Spindles	Standard
Color LCD Display with Basic Keyboard (English Language)	Standard
Color LCD Display with Basic Keyboard (French, German, Italian or Spanish Language)	Optional
Mechanical Run Meter	Standard
On-Screen "HELP" Functions for Alarms	Standard
Program Protected	Standard
Run Time and Parts Counter	Optional
Self-Diagnosis Function	Standard
Spindle Load Meter	Standard
Spindle Orient on Both Spindles	Standard

TWIN SPINDLE/TWIN TURRET MULTI-TASKING TURNING CENTER

Machine Configuration	PTT 42 Metric (A2-5)	PTT 51 Metric (A2-6)
Capacity		
Spindle Nose Configuration	A2-5	A2-6
Draw Tube Type	Hydraulic	Hydraulic
Maximum Swing Over Way Cover	205 mm	205 mm
Through Draw Tube Capacity	42 mm	52 mm
Part Weight w/ Chuck (Fixture)	34 Kg	34 Kg
Machining Dia - Max-Turret-Upper	218 mm	218 mm
Machining Dia - Max-Turret-Lower	198 mm	198 mm
Turning Length - Max-Turret-Upper (With Collet Adaptation Chuck)	435 mm	409 mm
Part Accuracy		
Roundness	2 micron	2 micron
Surface Finish Ra	0.8 micron	0.8 micron
Total Part Variation on Dia (150mm/5.91")	15 micron	15 micron
Main Spindle/Head		
Type	Belted	Belted
Spindle Nose	A2-5	A2-6
Spindle Hole Thru	56 mm	65.5 mm
Front Bearing Bore	85 mm	90 mm
Motor (FANUC) Standard	Fanuc ai 1 8/8000	Fanuc ai 1 8/8000
Max Speed/Base Speed	6000/1151 rpm	5000/992 rpm
Power @ Spindle (Continuous)	7.5 KW	7.5 KW
Power @ Spindle (30 Min)	11 KW	11 KW
Torque @ Spindle (Continuous)	62 Nm	72 Nm
Torque at Spindle (20 Min)	91 Nm	105 Nm
Belt Drive Ratio (Motor/Spindle)	1:3:1 (56:43)	1:51:1 (65:43)
Slides		
Z1, Z2 Axis, Fanuc		
Travel Z	508 mm	508 mm
Rapid Traverse Z	40 m/min	40 m/min
Axis Thrust Z (Max)	6785 N	6785 N
Drive Ratio	1:1	1:1
X, X2 Axis, Fanuc		
Travel X	143 mm	143 mm
Travel X2	133 mm	133 mm
Rapid Traverse X, X2	24 m/min	24 m/min
Axis Thrust X, X2 (Max)	11309 N	11309 N
Drive Ratio X	1:1	1:1
Drive Ratio X2	1:1 (37:37)	1:1 (37:37)
Y Axis, Fanuc		
Travel Y	± 30 mm	± 30 mm
Rapid Traverse Y	24 m/min	24 m/min
Axis Thrust Y (Max)	11309 N	11309 N
Drive Ratio	1:1	1:1
X, X2, Z, Z2, Y Axis		
Position Accy / Total Travel (ISO 230-2)	0.01 mm	0.01 mm
Repeatability (ISO 230-2)	0.005 mm	0.005 mm
Hydraulic Cylinder		
Type	Hydraulic	Hydraulic
Stroke	15 mm	22 mm
Min Pressure	3 Kg/cm ²	3 Kg/cm ²
Max Pressure	40 Kg/cm ²	40 Kg/cm ²
Thru Hole Size w/ Draw Tube	45 mm	52 mm
Operating Force (Max)	3200 kgf	5500 kgf
Operating Force (Min)	240 kgf	412 kgf
Max RPM	7000 rpm	6200 rpm

Machine Configuration	PTT 42 Metric (A2-5)	PTT 51 Metric (A2-6)
Machine Dimensions		
Spindle CL Height	1080 mm	1080 mm
Length w/o CHIP CONVEYOR	3761 mm	3761 mm
Length w/ CHIP CONVEYOR	4272 mm	4272 mm
Width	2034 mm	2034 mm
Height	2018 mm	2018 mm
Weight	7500 Kgs	7500 Kgs
Required Floor Space	8.2 m ²	8.2 m ²
Base		
Material	Cast Iron	Cast Iron
Slide Configuration	60 Slant with Z On	60 Slant with Z On
Width of Ways (Carriage-Guide)	369 mm	369 mm
Weight of Base (Approx)	2325 Kgs	2325 Kgs
Coolant Facilities		
Reservoir Capacity	400 L	400 L
Turret/Top Plate		
Type	BMT45	BMT45
Clamp Method	Hydraulic	Hydraulic
Index Motor	Servo Motor	Servo Motor
Index Time Next Station (Unlock, Index & Lock)	0.69 Sec	0.69 Sec
Index Repeatability (Return to Same Station)	±1.6 Arc Sec	±1.6 Arc Sec
Indexing Accuracy (Next Station)	±4 Arc Sec	±4 Arc Sec
Rotating Toolholder Coupling	DIN 1809 (Tenon)	DIN 1809 (Tenon)
Number of Stations	16	16
Square Shank Size	20 mm	20 mm
Round Shank Size	32	32
Live Tool Motor (FANUC) Standard		
Motor	Fanuc α2/10000i	Fanuc α2/10000i
Max Speed	5000 rpm	5000 rpm
Max Torque	23.8 Nm	23.8 Nm
Max Tap Dia	14 mm	14 mm
Sub-Spindle		
Motor	Fanuc ai 1 8/8000	Fanuc ai 1 8/8000
Type	Belted	Belted
Spindle Nose	A2-5	A2-5
Thru Hold	56 mm	56 mm
Max Speed/Base Speed	6000/1152 rpm	6000/1152 rpm
Power @ Spindle (Continuous)	7.5 kW	7.5 kW
Power @ Spindle (30 min)	11 kW	11 kW
Torque @ Spindle (Continuous)	61 Nm	61 Nm
Torque @ Spindle (30 min)	91 Nm	91 Nm
Sub-Spindle Hydraulic Cylinder		
Type	Hydraulic	Hydraulic
Stroke	15 mm	15 mm
Min Pressure	3 Kg/cm ²	3 Kg/cm ²
Max Pressure	40 Kg/cm ²	40 Kg/cm ²
Thru Hole Size w/ Draw Tube	45 mm	45 mm
Operating Force (Max)	3200 kgf	3200 kgf
Operating Force (Max)	240 kgf	240 kgf

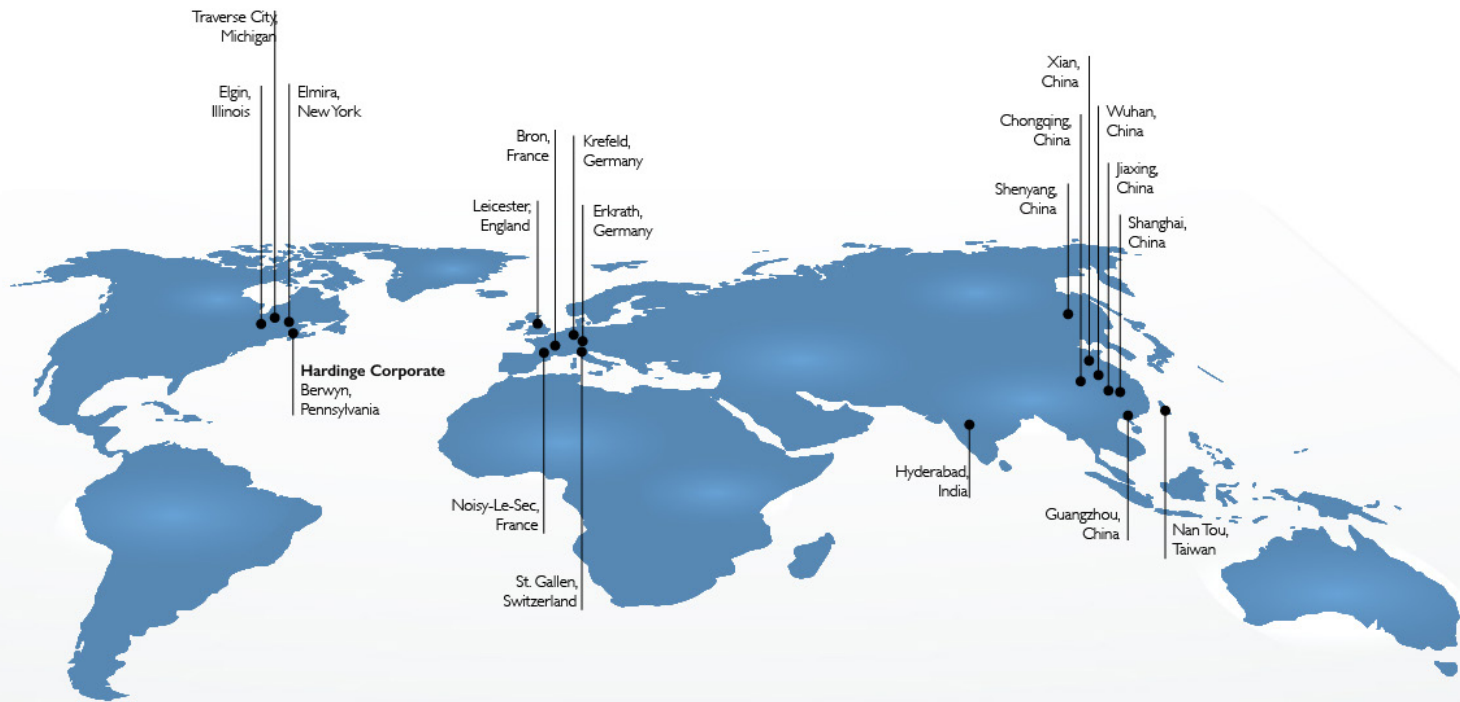

HARDINGE WORLDWIDE

Hardinge is a leading international provider of advanced metal-cutting solutions. We provide a full spectrum of highly reliable CNC turning, milling, and grinding machines as well as technologically advanced work-holding accessories.

The diverse products we offer enable us to support a variety of market applications in industries including aerospace, agricultural, automotive, construction, consumer products, defense, energy, medical, technology, transportation and more.

We've developed a strong global presence with manufacturing operations in North America, Europe, and Asia. Hardinge applies its engineering and applications expertise to provide your company with the right machine tool solution and support every time.

AMERICAS

Pennsylvania
Hardinge Corporate
1235 Westlakes Drive
Suite 410
Berwyn, PA 19312

New York

Hardinge
One Hardinge Drive
Elmira, NY 14903
P. 800-843-8801
E. info@hardinge.com
www.hardinge.com

Illinois

Hardinge
1524 Davis Road
Elgin, IL 60123
P. 800.843.8801

ASIA

China
Hardinge Machine
(Shanghai) Co. Ltd.
1388 East Kangqiao Road
Pudong, Shanghai 201319
P. 0086 21 3810 8686

Taiwan

Hardinge Machine Tools
B.V., Taiwan Branch
4 Tzu Chiang 3rd Road
Nan Tou City 540
Taiwan
P. 886 49 2260 536
E. cs@hardinge.com

EUROPE

France
Jones & Shipman SARRL
8 Allee des Ginkgos
BP 112-69672
Bron Cedex, France
P. +33 (0)4 72 81 26 60

Germany

Hardinge GmbH
Europark Fichtenhain A 13c
47807 Krefeld
P. +49 (0)2151 496490
E. info@hardinge-gmbh.de

Switzerland

L. Kellenberger & Co. AG
Heiligkreuzstrasse 28
9008 St. Gallen
Switzerland
P. +41 (0)71 2429111
E. info@kellenberger.net

United Kingdom

Jones & Shipman
Hardinge Ltd.
Europark, Unit 4 Watling Street
Rugby CV23 0AL
United Kingdom
P. +44 116 201 3000
E. info@joneshipman.com

